

**FRONT VIEW  
FEMALE INSERT CONFIGURATION CHART**

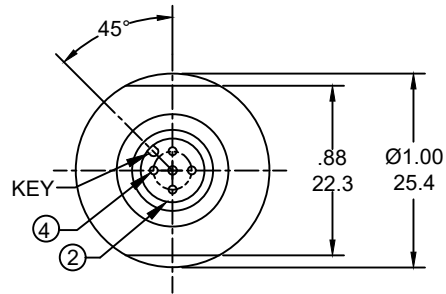
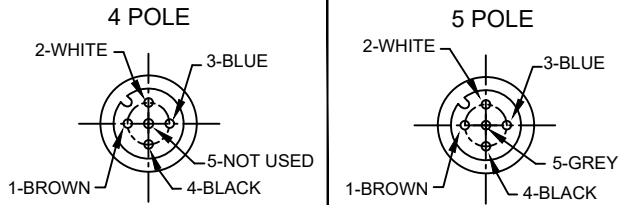

**NOTES:**

- MATERIAL: AS NOTED
- FINISH: AS NOTED
- ELECTRICAL:  
VOLTAGE: 4 & 5P 250V  
CURRENT: 4A
- TEMP RATING: -20°C TO +105°C (A3)
- PROTECTION: IP67 (WHEN MATED)
- UL LISTED FILE: E152210  
CSA CERTIFIED FILE: LR6837
- ALL DIMENSIONS ARE FOR REFERENCE UNLESS TOLERANCED OR NOTED OTHERWISE

| SAP P/N #  | ENGINEERING P/N | FINISHED LENGTH   |
|------------|-----------------|-------------------|
| 1200700168 | 8R4000A16M005   | 0.5M [ 1FT 8 IN ] |
| 1200704013 | 8R5000A16M030   | 3M [ 9FT 10 IN ]  |
| 1200700172 | 8R4000A16M060   | 6M [ 19FT 8 IN ]  |

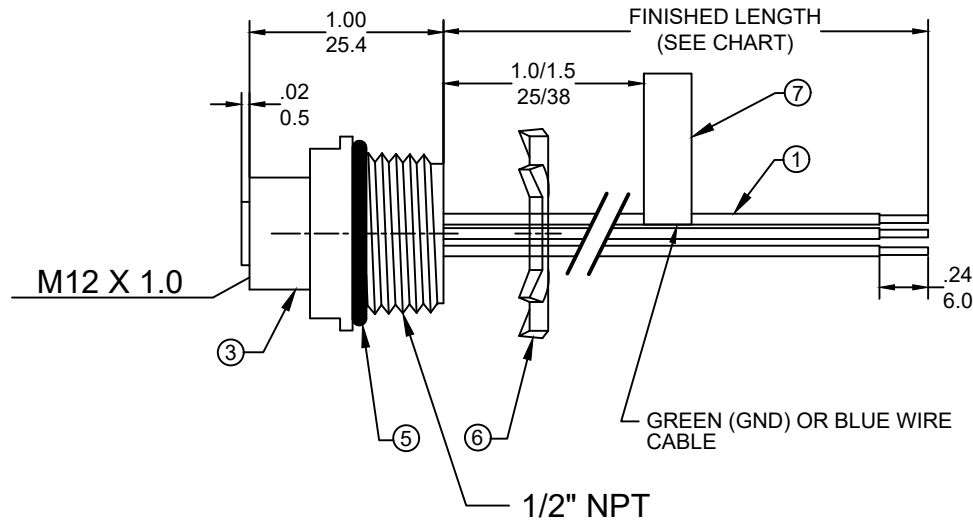

**KNOCKOUT HOLE**

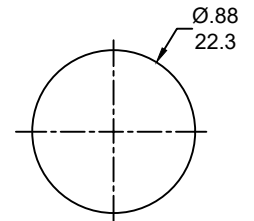

**PART NO. MATRIX**

**8R4000A16M005**

POLES  
(4, 5)

LENGTH:  
M005= 0.5 METER  
M010= 1 METER  
M100= 10 METER

(A3)

**CABLE LENGTH TOLERANCES**

|                          |                         |
|--------------------------|-------------------------|
| >.3M [1FT]:              | +19mm-0 [ +.75in-0]     |
| .3 - .9M [1 - 3FT]:      | +44.5mm-0 [+1.75in-0]   |
| .9 - 1.8M [3 - 6FT]:     | +55.6mm-0 [+2.19in-0]   |
| 1.8 - 3.7M [6 - 12FT]:   | +88.9mm-0 [+3.50in-0]   |
| 3.7 - 7.3M [12 - 24FT]:  | +165.1mm-0 [+6.50in-0]  |
| 7.3-14.6M [24 - 48FT]:   | +317.5mm-0 [+12.50in-0] |
| 14.6 - 30.5M [48-100FT]: | +622.3mm-0 [+24.50in-0] |
| OVER 30M [100FT]         | +2% OF FINISHED LENGTH  |

| ITEM | COMPONENT         | MATERIAL      | FINISH           |
|------|-------------------|---------------|------------------|
| 7    | LABEL             | VINYL         | BLACK/YELLOW     |
| 6    | LOCKNUT           | STEEL         | ZINC PLATED      |
| 5    | O-RING            | NITRILE       | BLACK            |
| 4    | CONTACT SOCKET    | COPPER ALLOY  | GOLD OVER NICKEL |
| 3    | SHELL FM M12x1    | ZINC DIE CAST | YELLOW           |
| 2    | FEMALE INSERT     | NYLON         | BLACK            |
| 1    | WIRE #18 (UL1569) | PVC           | SEE FACE VIEW    |

|                 |    |              |            |          |
|-----------------|----|--------------|------------|----------|
| DOCUMENT STATUS | P1 | RELEASE DATE | 2020/09/15 | 20:43:13 |
|-----------------|----|--------------|------------|----------|

| FUNCTIONAL SYMBOLS                                   |         |         |                                                                                                                                               |                                                                                                                                                                                     |  |        |  |                 |  |                |  |              |  |
|------------------------------------------------------|---------|---------|-----------------------------------------------------------------------------------------------------------------------------------------------|-------------------------------------------------------------------------------------------------------------------------------------------------------------------------------------|--|--------|--|-----------------|--|----------------|--|--------------|--|
| $F_A=0$                                              | $F_C=0$ | $F_P=0$ | THIS DRAWING CONTAINS INFORMATION THAT IS PROPRIETARY TO MOLEX ELECTRONIC TECHNOLOGIES, LLC AND SHOULD NOT BE USED WITHOUT WRITTEN PERMISSION |                                                                                                                                                                                     |  |        |  |                 |  |                |  |              |  |
| DIMENSION UNITS                                      |         | SCALE   |                                                                                                                                               | CURRENT REV DESC: REMOVED 3P DETAILS. UPDATED TEMP RATING. ADDED TOL CHART. MODIFIED MATERIAL TABLE.                                                                                |  |        |  |                 |  |                |  |              |  |
| INCH/MM                                              |         | NTS     |                                                                                                                                               | EC NO: 643513<br>DRWN: ABENJAMINLW 2020/07/31<br>CHK'D: RSTONE 2020/08/28<br>APPR: BWOODMAN 2020/09/15<br>INITIAL REVISION:<br>DRWN: RSTONE 2012/11/05<br>APPR: JFMURPHY 2013/02/07 |  |        |  |                 |  |                |  |              |  |
| GENERAL TOLERANCES (UNLESS SPECIFIED)                |         |         |                                                                                                                                               |                                                                                                                                                                                     |  |        |  |                 |  |                |  |              |  |
|                                                      | mm      | INCH    |                                                                                                                                               |                                                                                                                                                                                     |  |        |  |                 |  |                |  |              |  |
| 4 PLACES                                             | ±----   | ±----   |                                                                                                                                               |                                                                                                                                                                                     |  |        |  |                 |  |                |  |              |  |
| 3 PLACES                                             | ±----   | ±----   |                                                                                                                                               |                                                                                                                                                                                     |  |        |  |                 |  |                |  |              |  |
| 2 PLACES                                             | ±0.3    | ±0.01   |                                                                                                                                               |                                                                                                                                                                                     |  |        |  |                 |  |                |  |              |  |
| 1 PLACE                                              | ±0.3    | ±----   |                                                                                                                                               |                                                                                                                                                                                     |  |        |  |                 |  |                |  |              |  |
| 0 PLACES                                             | ±----   | ±----   |                                                                                                                                               |                                                                                                                                                                                     |  |        |  |                 |  |                |  |              |  |
| ANGULAR TOL ± 2.0 °                                  |         |         |                                                                                                                                               | THIRD ANGLE PROJECTION                                                                                                                                                              |  |        |  |                 |  |                |  |              |  |
| DRAFT WHERE APPLICABLE MUST REMAIN WITHIN DIMENSIONS |         |         |                                                                                                                                               | DRAWING                                                                                                                                                                             |  | SERIES |  | MATERIAL NUMBER |  | CUSTOMER       |  | SHEET NUMBER |  |
|                                                      |         |         |                                                                                                                                               | A-SIZE                                                                                                                                                                              |  | 120070 |  | SEE CHART       |  | GENERAL MARKET |  | 1 OF 1       |  |

**molex**

MICRO-CHANGE RECEPTACLE, A-SIZE,  
4-5 POLE, FEMALE, STRAIGHT, SINGLE KEY,  
18 AWG

**PRODUCT CUSTOMER DRAWING**

| DOCUMENT NUMBER | DOC TYPE | DOC PART | REVISION |
|-----------------|----------|----------|----------|
| SD-120070-043   | PSD      | 001      | A3       |