

RoHS Compliant
Pb - Lead Free
AEC-Q200 Qualified

Ltr	Revisions	Date	Appr

Electrical Specifications:

Frequency Range		10.000 to 150.000	MHz
Mode of Oscillation	Fundamental	10.000 to 54.000	
	Thrid Overtone	54.000 to 150.000	
Frequency Tolerance at 25°C		±50	PPM Max
Frequency Stability over Temperature Range		±100	
Operating Temperature Range		-40 to +125	° C
Storage Temperature Range		-55 to +125	
Aging		±3	PPM Max/Year
Load Capacitance		7 to 32 and Series Resonance	pF
Shunt Capacitance		3.0	
Equivalent Series Resistance (ESR)		See ESR Table	Ohms
Drive Level		100	uW Typ
Insulation Resistance		500 at at 100 Vdc ± 15 Vdc	M Ohms

Frequency Range and ESR Values:

Frequency Range in MHz	ESR Ohm Max	Mode of Operation	Frequency Range in MHz	ESR Ohm Max	Mode of Operation
10.000 to 11.999	150	Fundamental	54.000 to 99.999	150	3rd Overtone
12.000 to 15.999	80	Fundamental	100.000 to 124.999	100	3rd Overtone
16.000 to 19.999	60	Fundamental	125.000 to 150.000	80	3rd Overtone
20.000 to 24.999	50	Fundamental			
25.000 to 53.999	40	Fundamental			
54.000 to 64.000	30	Fundamental			



11-3 Chien-Kuo Rd T.E.P.Z. 4027 Taiwan, ROC

All dimensions are millimeters.

CAD: TCR

Review: EG

Appr: JL

Page: 1/4 Date: Dec. 9, 2013

Specification Title:

**Microprocessor Crystal Unit
Automotive Temperature Range
Low Profile
3.2 x 2.5 millimeter Surface Mount
General Product Specification**

Part Number: C3E X1 Series

Mechanical Outline:

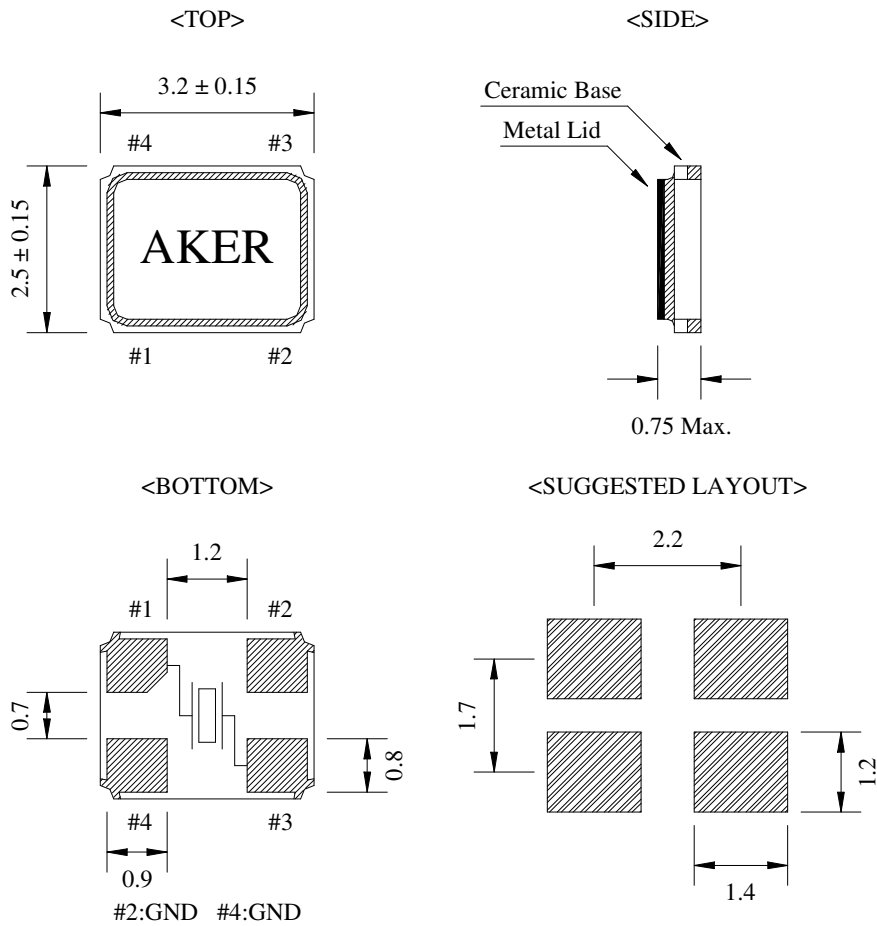

**Package is Seam Sealed Ceramic-Metal.
Dimensions are millimeters.**

Carrier Tape Dimensions:

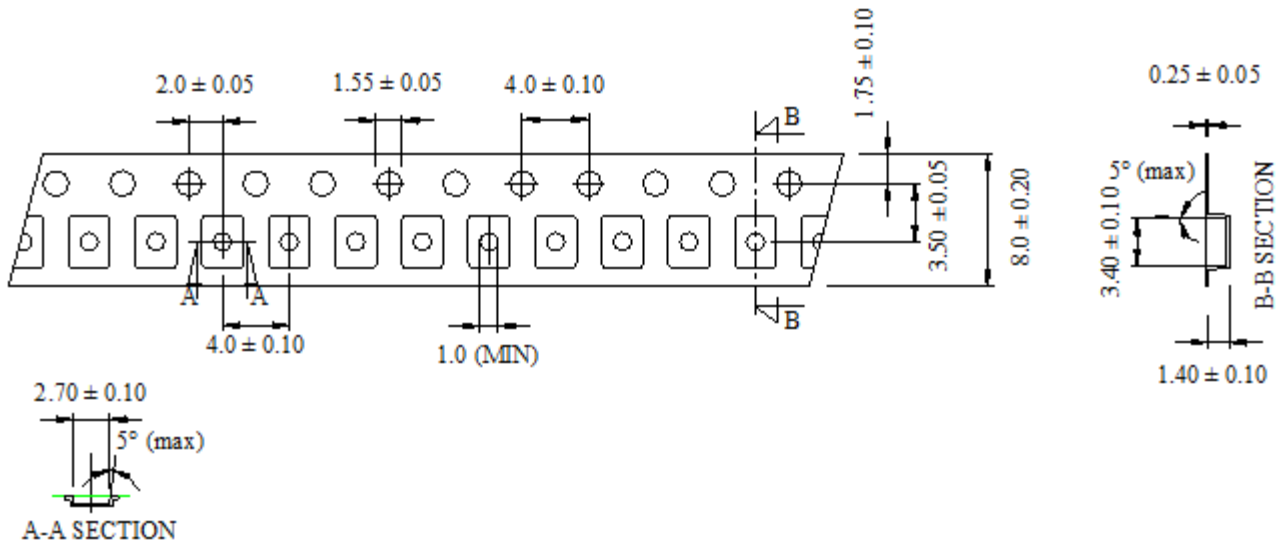

Dimensions are millimeters.

Solder Reflow Characteristics:

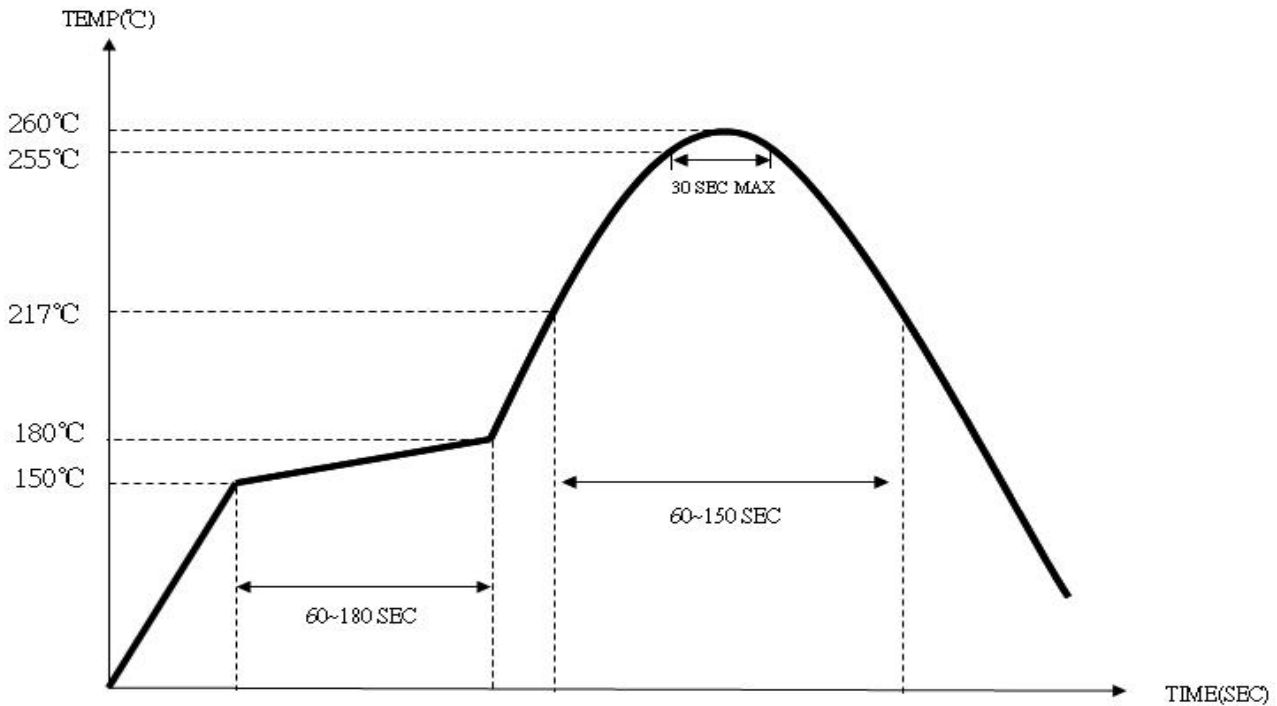

How to build a Part Number:

Series		C	Parameter
Package		3E	3.2 x 2.5 mm
		-	
Frequency		10.000 to 150.000	MHz
		-	
Load Capacitance		7	7 pF
		10	10 pF
		12	12 pF
		16	16 pF
		18	18 pF
		20	20 pF
		32	32 pF
		S	Series
		-	
Frequency Tolerance		50	±50 PPM
Frequency Stability		100	±100 PPM
		-	
Mode of Oscillation		See Notes	Fundamental
		3	Third Overtone
		-	
Temperature Range		X1	-40 to +125 °C
		-	
Packaging		M	250pcs Reel
		R	1000pcs Reel
		R3	3000pcs Reel

Part Number Example:

C3E-25.000-18-50100-X1-R

C3E- 2.5 x 3.2 mm SMD Seam Seal Crystal Unit

25.000 MHz Nominal Frequency

18 pF Load Capacitance

50100: ±50 PPM Frequency Tolerance and ±100 PPM Frequency Stability

X1: -40 to +125° C Temperature Range

R: Tape and Reel Packaging - 1000pcs

Notes:.

- 1- Product is shipped in Tape and Reel configuration.**
- 2- Quantities less than 250pcs are shipped in tape.**
- 3- Specification subject to change without notice.**
- 4- Fundamental mode does not need to be included in Part Number description.**