

## Metallized Polypropylene Film Capacitor

**EZPE** series (Low profile type)



### Features

- High safety, Self-healing and Self-protecting function built-in
- Long product life, High reliability, High moisture resistance
- Low loss, Low ESR
- Flame retardant (Case and sealing resin)
- Low profile design
- RoHS compliant

### Recommended applications

#### For DC filtering, DC link circuit

- Solar inverters, Micro inverters
- Wind power generation
- Industrial power supplies
- Inverter circuit in appliances (Air Conditioners etc.)

### Construction

- Dielectric : Polypropylene film
- Electrodes : Metallized dielectric with segmented pattern
- Plastic case : UL94 V-0
- Sealing : UL94 V-0
- Terminals : Tinned wires, 2-pin and 4-pin versions

### Explanation of part number

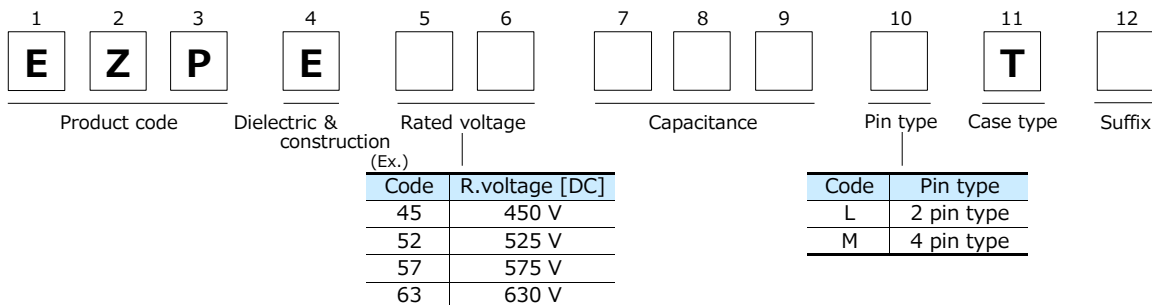

### Specifications

Category temperature range*1	-40 °C to +85 °C	
Rated voltage*2 [DC]	450 V, 525 V, 575 V, 630 V (Derating of rated voltage by more than 70 °C*3)	
Rated capacitance	450 V	66 μF
	525 V	29 μF
	575 V	12 μF
	630 V	10 μF
Capacitance tolerance	±15 %	
Withstand voltage	Between terminals : Rated voltage (V) × 150 % 10 s Terminal to case : 2000 V [AC] (50 Hz or 60 Hz), 10 s	
Insulation resistanc (IR)	CR ≥ 10,000 Ω·F (20 °C, 500 V [DC], 60 s)	

\*1 : The temperature of capacitor surface (case)

\*2 : Use for DC voltage only

\*3 : Refer to the page of "DC voltage derating"

**Dimensions**

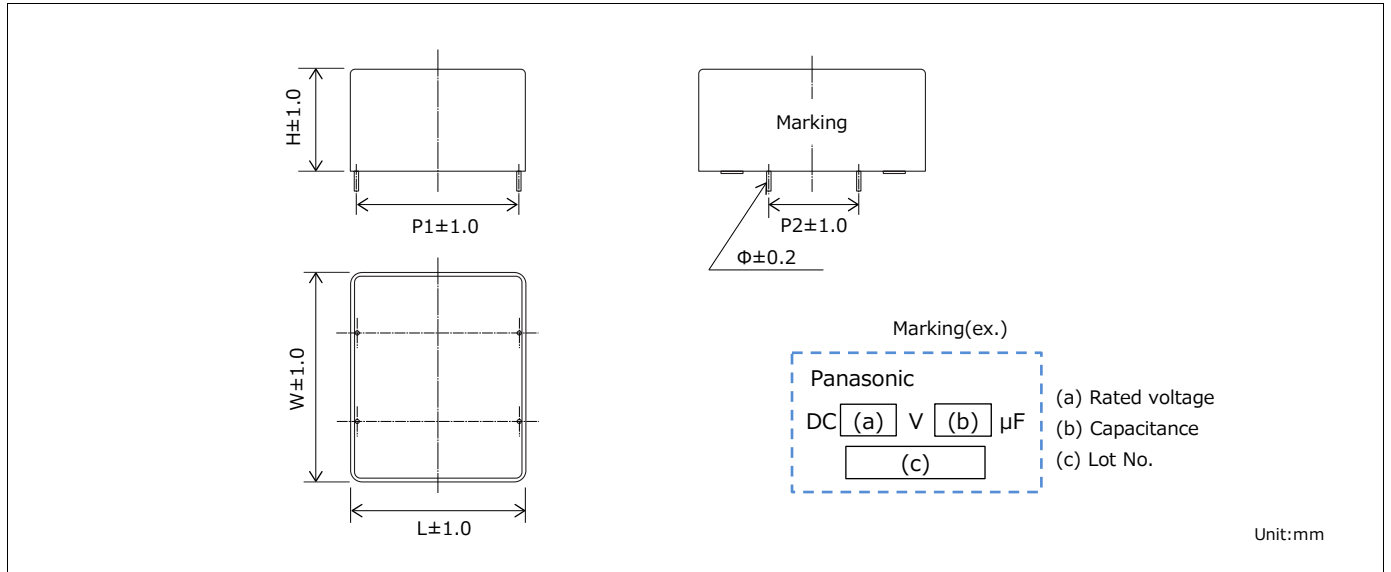

**Rating · Dimensions · Quantity**

■ Rated voltage [DC] : 450 V at 70 °C

Part No.	Capacitance (μF)	Dimensions (mm)						dv/dt [V/μs]	Permissible current		ESR*3 (mΩ)	tan δ*4 (%)	Mass (g)	Min. order Qty*5 (PCS)
		W	H	L	P1	P2	Φ		Peak current*1 (A <sub>o-p</sub> )	RMS current*2 (A rms)				
EZPE45666MTB	66	90.0	24.0	32.5	27.5	37.5	0.8	5	300	15.0	5.0	0.3	110	200

■ Rated voltage [DC] : 525 V at 70 °C

Part No.	Capacitance (μF)	Dimensions (mm)						dv/dt [V/μs]	Permissible current		ESR*3 (mΩ)	tan δ*4 (%)	Mass (g)	Min. order Qty*5 (PCS)
		W	H	L	P1	P2	Φ		Peak current*1 (A <sub>o-p</sub> )	RMS current*2 (A rms)				
EZPE52296MTB	29	48.5	23.5	37.0	34.0	20.3	0.8	14	400	3.0	7.0	0.4	50	400

■ Rated voltage [DC] : 575 V at 70 °C

Part No.	Capacitance (μF)	Dimensions (mm)						dv/dt [V/μs]	Permissible current		ESR*3 (mΩ)	tan δ*4 (%)	Mass (g)	Min. order Qty*5 (PCS)
		W	H	L	P1	P2	Φ		Peak current*1 (A <sub>o-p</sub> )	RMS current*2 (A rms)				
EZPE57126LTB	12	24.5	19.5	41.5	37.5	—	1.0	22	264	5.0	22.0	0.45	25	800

■ Rated voltage [DC] : 630 V at 70 °C

Part No.	Capacitance (μF)	Dimensions (mm)						dv/dt [V/μs]	Permissible current		ESR*3 (mΩ)	tan δ*4 (%)	Mass (g)	Min. order Qty*5 (PCS)
		W	H	L	P1	P2	Φ		Peak current*1 (A <sub>o-p</sub> )	RMS current*2 (A rms)				
EZPE63106LTB	10	24.5	19.5	41.5	37.5	—	1.0	21	210	3.0	22.0	0.45	25	800

\*1 : When rising temperature of capacitor surface by continuous peak current (included pulse current), use within limit specified for temperature of capacitor surface and self heating temperature rise.

\*2 : Maximum RMS current @70 °C, 10 kHz  
Use within limit for self heating temperature rise at capacitor surface.

\*3 : Typical values @ 20 °C, 10 kHz ESR : less than 2.5×ESR typ

\*4 : Maximum dissipation factor @ 20 °C, 1 kHz

\*5 : Minimum order quantity consists of 4 packing units.

**Guidelines and precautions regarding the technical information and use of our products described in this online catalog.**

- If you want to use our products described in this online catalog for applications requiring special qualities or reliability, or for applications where the failure or malfunction of the products may directly jeopardize human life or potentially cause personal injury (e.g. aircraft and aerospace equipment, traffic and transportation equipment, combustion equipment, medical equipment, accident prevention, anti-crime equipment, and/or safety equipment), it is necessary to verify whether the specifications of our products fit to such applications. Please ensure that you will ask and check with our inquiry desk as to whether the specifications of our products fit to such applications use before you use our products.
- The quality and performance of our products as described in this online catalog only apply to our products when used in isolation. Therefore, please ensure you evaluate and verify our products under the specific circumstances in which our products are assembled in your own products and in which our products will actually be used.
- If you use our products in equipment that requires a high degree of reliability, regardless of the application, it is recommended that you set up protection circuits and redundancy circuits in order to ensure safety of your equipment.
- The products and product specifications described in this online catalog are subject to change for improvement without prior notice. Therefore, please be sure to request and confirm the latest product specifications which explain the specifications of our products in detail, before you finalize the design of your applications, purchase, or use our products.
- The technical information in this online catalog provides examples of our products' typical operations and application circuits. We do not guarantee the non-infringement of third party's intellectual property rights and we do not grant any license, right, or interest in our intellectual property.
- If any of our products, product specifications and/or technical information in this online catalog is to be exported or provided to non-residents, the laws and regulations of the exporting country, especially with regard to security and export control, shall be observed.

**<Regarding the Certificate of Compliance with the EU RoHS Directive/REACH Regulations>**

- The switchover date for compliance with the RoHS Directive/REACH Regulations varies depending on the part number or series of our products.
- When you use the inventory of our products for which it is unclear whether those products are compliant with the RoHS Directive/REACH Regulation, please select "Sales Inquiry" in the website inquiry form and contact us.

**We do not take any responsibility for the use of our products outside the scope of the specifications, descriptions, guidelines and precautions described in this online catalog.**

## PRECAUTION AND WARNING

- Please consult us in case that demand the specification of our company without fail and do the confirmation of the use condition and that exceeds the entry value and be indistinct when you use it.
- The film capacitors contain a film based dielectric which may be flammable under certain operating conditions. When in use, they can either emit smoke and/or ignite should the product be defective. It is recommended covering the surrounding resin with flame-resistant materials or case as needed particularly.
- In the event of troubles of other parts on the circuit such as shortening and opening, provide with proper means for preventing excessive voltage, current or temperature exceeding the rating from being applied to the film capacitor.
- Prior to use, please make sure that failure of the film capacitors does not have any negative effects on other surrounding electronic circuit components and devices that would possibly cause damage. Proper safety measures should be taken using fail-safe protective circuit designs to help prevent other devices of becoming unsafe.
  - Example:
    - a. State in which basic performance of automobiles (run, turn and stop)
    - b. False operations
    - c. Smoke emission/ignitions
- The Film Capacitor listed in this catalog(except for automotive series) are designed and manufactured specifically for general electronic devices, including audio-video equipment, home appliance, office equipment and data communication equipment etc.. Accordingly, it is strongly recommended that the user contact us in advance if the parts are to be used for the following devices(items 1 -12), which require having advanced security measures. The capacitor for automotive can be used for automobiles such as xEV.
  - (1) Transport Equipment (motor vehicles, airplanes, trains, ships, traffic signal controllers)
  - (2) Medical Equipment (life-support equipment, pacemakers for the heart, dialysis controllers)
  - (3) Aircraft Equipment, Aerospace Equipment (airplanes, artificial satellites, rockets, etc.)
  - (4) Submarine Equipment (submarine repeating equipment, etc.)
  - (5) Generation Control Equipment (equipment for atomic/hydraulic/heat power plants)
  - (6) Information Processing Equipment (large scale computer system)
  - (7) Electric Heating Appliance, Burning Apparatus
  - (8) Rotary Motion Equipment
  - (9) Security Systems
  - (10) Robots
  - (11) Lighting Equipment
  - (12) And any similar types of equipment
- If used in a specific appliance that requires an extremely high reliability directly relating with any life-supporting equipment like electronic aviation controllers, automotive driving controllers and engine controllers, please consult us and use within the conditions designated in the specification. However the chip type capacitor should not be used in these appliances.

### Note:

1. Technical information in this catalog is intended to convey examples of typical performances and/or applications, and is not intended to convey patents rights, if any.
2. For the products, which are controlled items subject to the Foreign Exchange and Foreign Trade Control Law, the export permission according to the Law is necessary.
3. Note of ozone depleting substances of class1 (ODS) under the Montreal Protocol is used in manufacturing process of Device Solutions Business Division, Panasonic Corporation.

### ■ AEC-Q200 compliant

The products are tested based on all or part of the test conditions and methods defined in AEC-Q200. Please consult with Panasonic for the details of the product specification and specific evaluation test results, etc., and please review and approve Panasonic's product specification before ordering.

### \* Intellectual property right

We, Panasonic Group are providing the product and service that customers can use without anxiety, working positively on the protection of our products under intellectual property rights.

Representative patents relating to xEV Film capacitors are as follows :

US Paten No.7027286, No.8315031, No.8861177, No.9240279, No.10475585  
JP Patent No.4784464, No.4930099, No.4946618, No.5391797