

# PWM Controller

## Features

### Reduces system power consumption and fan noise

For PWM fan speed control, a PWM control circuit needs to be newly designed and configured.

By using this product, however, PWM control function fans can be fully utilized without the need for preparing new circuits, contributing to reducing the system power consumption and the fan noise.

### Can be common-powered by the fan power supply

The controller can be powered by the fan power supply of rated voltage 12, 24, and 48 VDC, and no separate supply is required.

### Maximum of four fans connectable

Up to four fans with PWM control function can be connected and controlled.

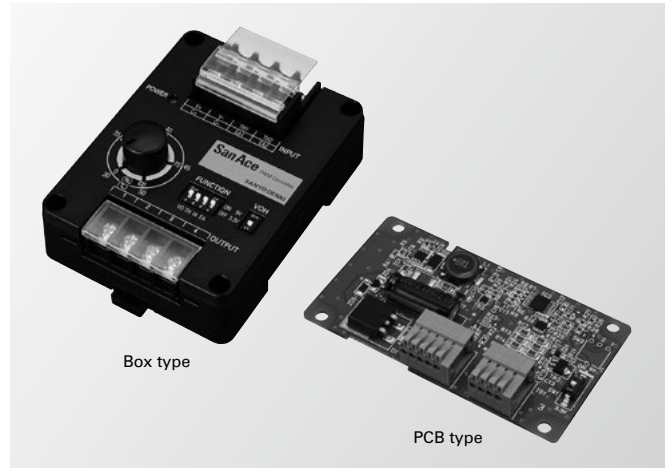

## Specifications

### Box type

Model no.	9PC8666X-S001	9PC8666X-S101
Size [mm]	86 (H)×66 (W)×38 (D)	
Rated voltage [V]	12/24/48	
Power consumption [W]	0.2 <sup>(1)</sup>	
Operating temperature [°C]	-20 to +70	
Input terminal	Input voltage range [V] (V+, V-)	7 to 60
	Control voltage range [V]	0 to 5.5
Output terminal	PWM signal output	V <sub>OH</sub> (high level voltage): 3.3 or 5 VDC selectable
	PWM frequency [kHz]	25
	Output current	20 mA max. (total sum of 4 terminals)
	Output breakdown voltage [V]	6.5
	No. of connectable fans	Up to 4 fans
Control functions <sup>(2)</sup>	Voltage control, Internal adjustment (variable resistor) control, External adjustment (variable resistor) control <sup>(3)</sup> , Thermistor control <sup>(3)</sup>	
Mounting method	DIN rail mounting or screw mounting	
Mass [g]	110	
Material	Case: Plastic	

### PCB type

Model no.	9PC8045D-V001	9PC8045D-R001	9PC8045D-T001	9PC8045D-V101	9PC8045D-R101	9PC8045D-T101
Size [mm]	80 (H)×45 (W)×17 (D)					
Rated voltage [V]	12/24/48					
Power consumption [W]	0.2 <sup>(1)</sup>					
Operating temperature [°C]	-20 to +70					
Input terminal	Input voltage range [V] (V+, V-)	7 to 60				
	Control voltage range [V]	0 to 5.5				
Output terminal	PWM signal output	V <sub>OH</sub> (high level voltage): 3.3 or 5 VDC selectable				
	PWM frequency [kHz]	25	1			
	Output current	20 mA max. (total sum of 4 terminals)				
	Output breakdown voltage [V]	6.5				
	No. of connectable fans	Up to 4 fans				
Control functions	Voltage control	Variable resistor control <sup>(3)</sup>	Thermistor control <sup>(3)</sup>	Voltage control	Variable resistor control <sup>(3)</sup>	Thermistor control <sup>(3)</sup>
Mounting method	Screw mounting					
Mass [g]	27					
Material	PCB: FR-4					

(1) When output terminals are turned on. (2) Control functions are mutually exclusive for Box type.

(3) Variable resistor and thermistor are not supplied with the controller and need to be prepared separately.

Note: Be noted that if applied input voltage or frequency is out of range of the connected fan, how the fan speed responds to the PWM duty cycle may be altered.

## Front View (component names)

- Box type

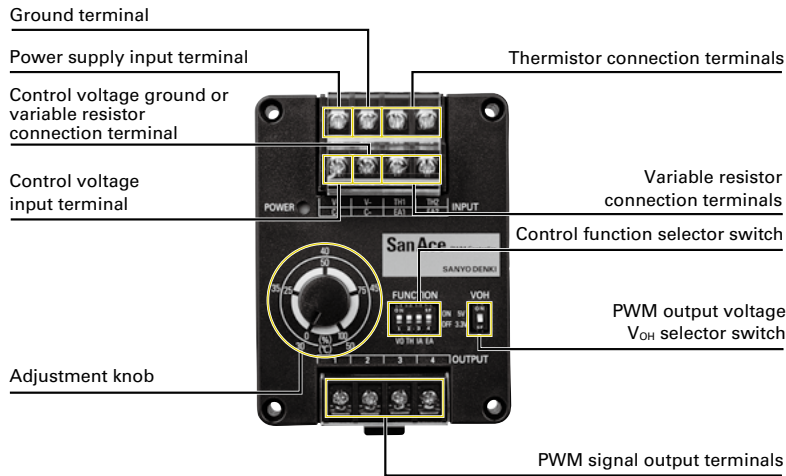

- PCB type

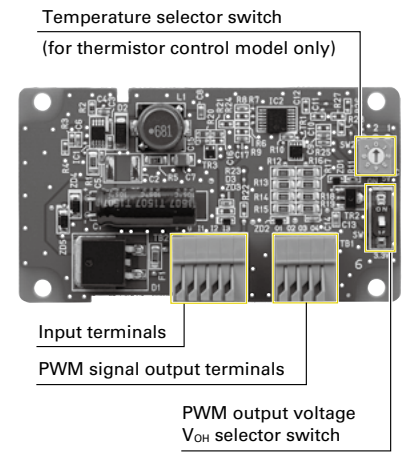

## Connection Examples and PWM Signal Output Characteristics

Controller can be common-powered by the power supply for 12, 24, and 48 VDC rated voltage fans. It can also be powered by a separate supply as long as both supplies share the same ground.

### Voltage control

Output duty cycle controlled with input voltage of 0 to 5 VDC. \*Ensure that the input voltage does not exceed 5.5 VDC.

- Box type

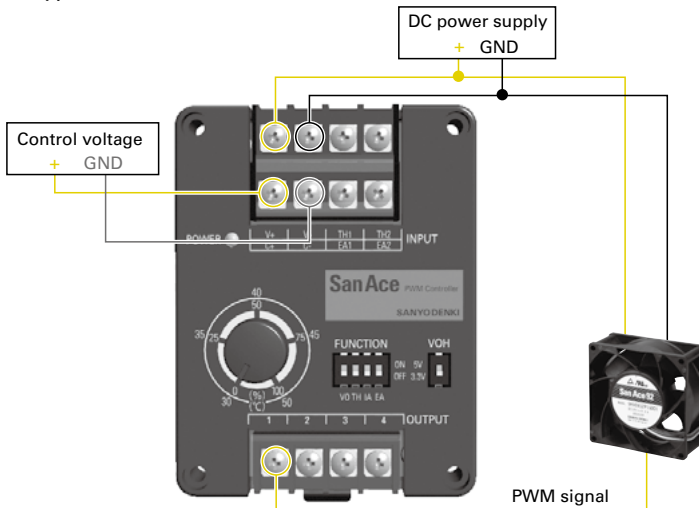

Control Voltage - Output Duty Cycle Characteristics

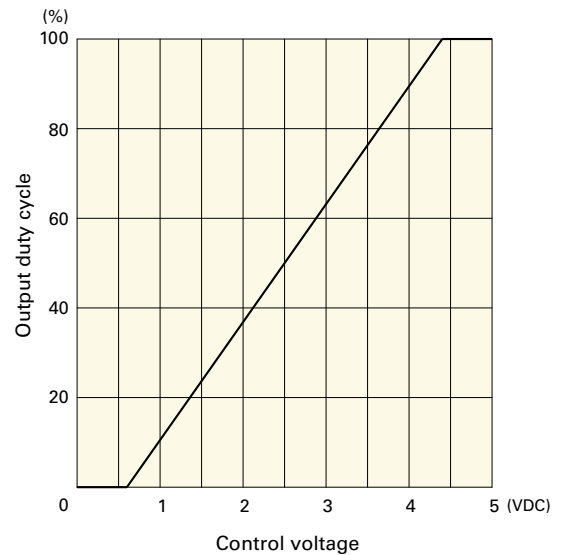

- PCB type (Model no.: 9PC8045D-V001)

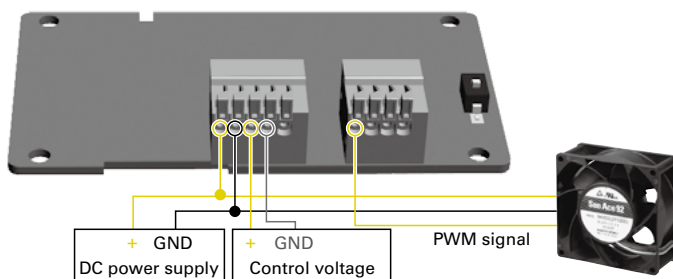

## Internal adjustment (variable resistor) control

Output duty cycle controlled with the adjustment knob.

- Box type

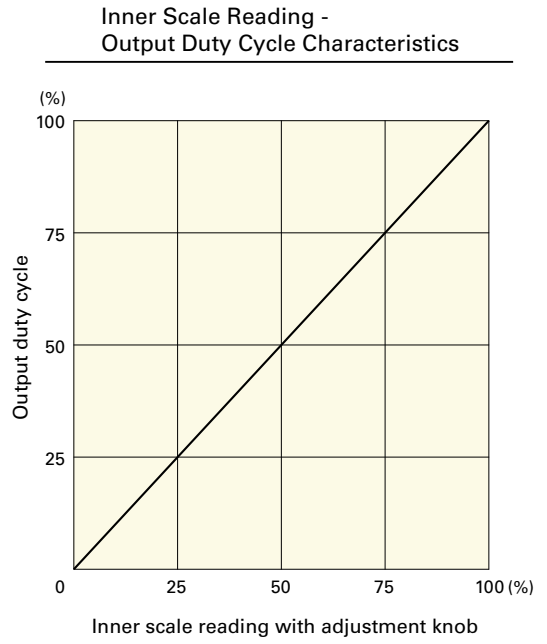
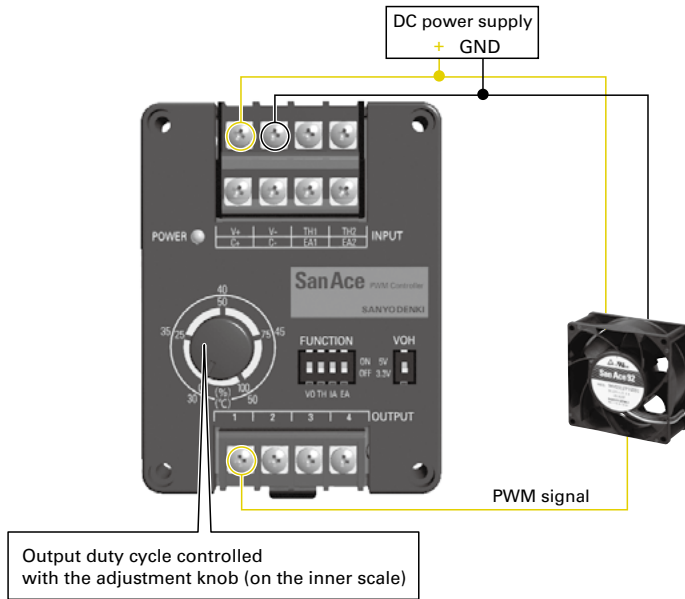

## PWM Controller

### External adjustment (variable resistor) control

Output duty cycle controlled with variable resistor connected to terminals.

- Box type

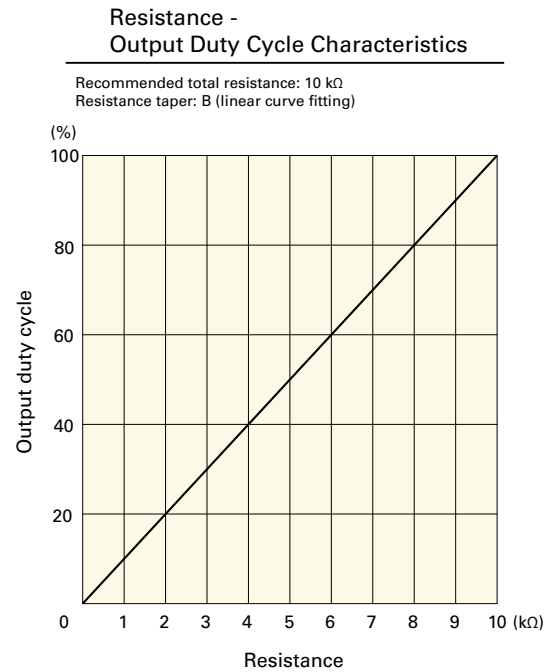
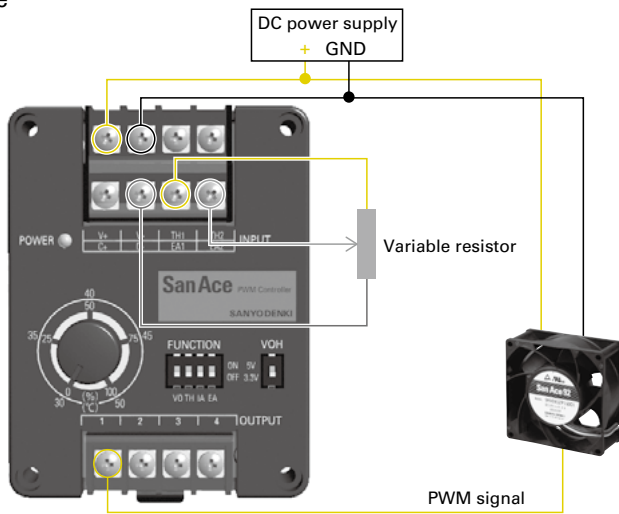

- PCB type (Model no.: 9PC8045D-R001)

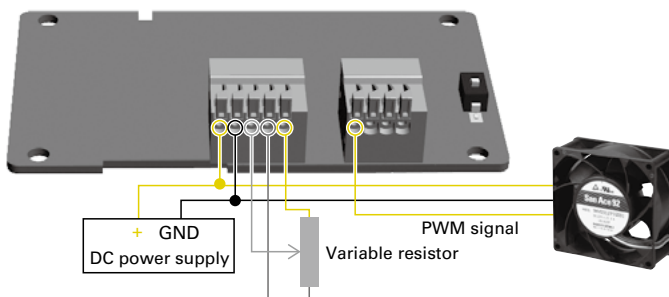

## Thermistor control

Automation control of output duty cycle in response to the temperature detected with an external thermistor.

- Box type

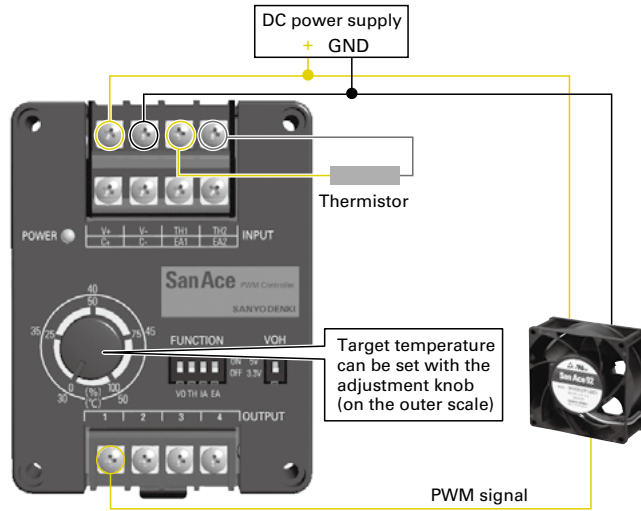

### Controlling Conditions

$T_{ST}$ : Temperature set with the adjustment knob (30 to 50°C)

$T_{TH}$ : Temperature detected with thermistor

Recommended thermistor conditions

Type: NTC

$R_{25}$  (Resistance at 25°C): 10 kΩ

B value:  $B_{25/85} = 3435$  K

Temperature conditions	Duty cycle	Fan rotational speed (For reference)
$T_{ST} < T_{TH}$	Increases	Increases
$T_{ST} > T_{TH}$	Decreases	Decreases
$T_{ST} \approx T_{TH}$	Maintained	Maintained

- PCB type (Model no.: 9PC8045D-T001)

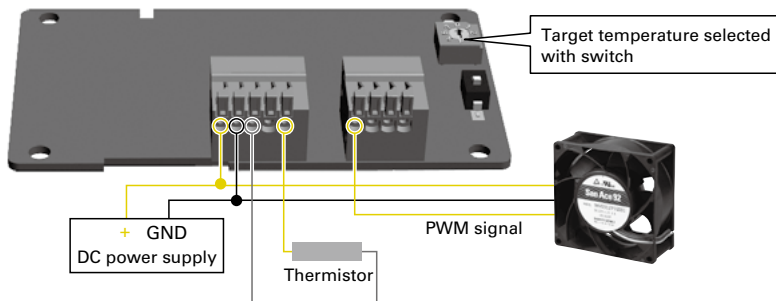

## Dimensions (unit: mm)

- Box type

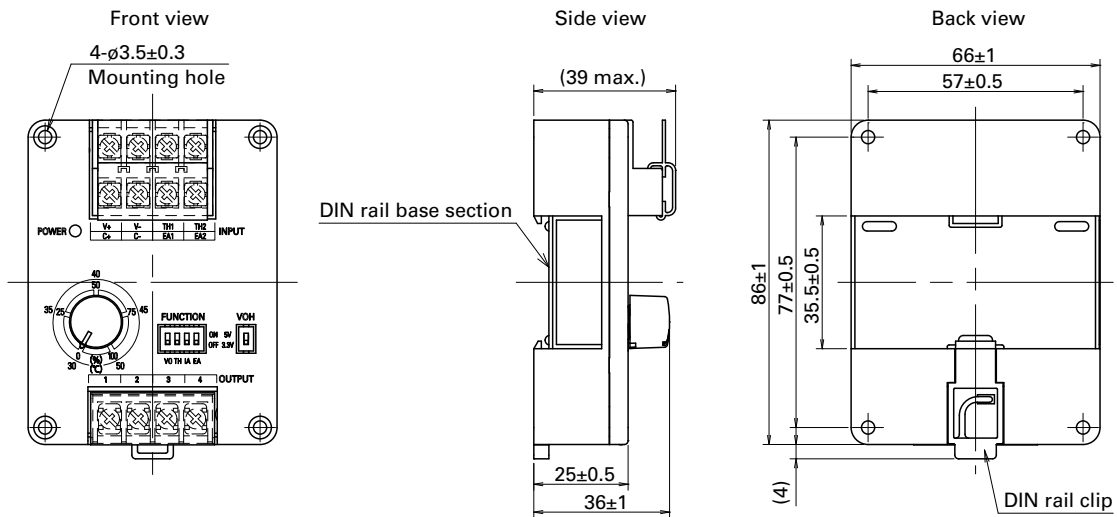

- PCB type

