

PGA309EVM-USB

This user's guide describes the characteristics, operation, and use of the PGA309EVM-USB evaluation module (EVM). This EVM is designed to evaluate the performance of the [PGA309](#), a voltage output, programmable sensor conditioner. This document covers all pertinent areas involved to properly use this EVM board, allowing for user evaluation suitable to a variety of applications. This document also includes the physical printed circuit board (PCB) layout and circuit descriptions. A [schematic of the PGA309EVM-USB](#) is available as a separate download from the TI web site.

Contents

1	Introduction and Overview	2
2	System Setup	5
3	PGA309EVM-USB Hardware Setup	16
4	PGA309EVM-USB Software Overview	25

List of Figures

1	Hardware Included with the PGA309EVM-USB	3
2	PGA309EVM-USB Hardware Setup	5
3	PGA309_Test_Board Block Diagram	5
4	PGA309_Test_Board Schematic: Input Circuitry	7
5	PGA309_Test_Board Schematic: Power, Reference, and Digital Connections	8
6	PGA309_Test_Board Schematic: Output Circuitry	9
7	PGA309_Test_Board Schematic: Sensor Emulator Circuitry	10
8	PGA309_Test_Board Connections to USB-DAQ-Platform and EEPROM	11
9	Theory of Operation For USB-DAQ-Platform	16
10	PGA309EVM-USB Typical Hardware Connections	17
11	Connecting the Two EVM PCBs	18
12	Connecting Power to the EVM	19
13	Connecting the USB Cable	20
14	Default Jumper Settings (PGA309_Test_Board)	21
15	Default Jumper Settings (USB-DAQ-Platform)	22
16	PGA309EVM-USB Software: Block Diagram	26
17	PGA309EVM-USB Software: Registers Tab	27
18	PGA309EVM-USB Software: Set-Up Cal Tab	28
19	PGA309EVM-USB Software: Auto Calibrate Tab	29
20	PGA309EVM-USB Software: EEPROM Tab	30
21	PGA309EVM-USB Software: Set-Up Cal Tab with Select Model File Dialog	31
22	PGA309EVM-USB Software: Set-Up Cal Tab with Create Model Dialog	32
23	PGA309EVM-USB Software: Set-Up Cal Tab with Sensor Emulator Control Tool Dialog	33
24	PGA309EVM-USB Software: Set-Up Cal Tab with Configure DMM Interface Dialog	34
25	PGA309EVM-USB Software: Auto Calibrate Tab with Auto-Continue Feature Enabled	35
26	PGA309EVM-USB Software: Auto Calibrate Tab at Start of Calibration Process	36
27	PGA309EVM-USB Software: Auto Calibrate Tab with Calibration in Progress	37

Microsoft, Windows are registered trademarks of Microsoft Corporation.
All other trademarks are the property of their respective owners.

28	PGA309EVM-USB Software: Auto Calibrate Tab with Second Calibration in Progress	38
29	PGA309EVM-USB Software: Auto Calibrate Tab with Both Calibrations Complete	39
30	PGA309EVM-USB Software: Create Model, Select Pre-Cal File	40
31	PGA309EVM-USB Software: Create Model Dialog with Create Pre-Cal File Active	41
32	PGA309EVM-USB Software: Create Model Dialog with Create Sensor File Active	42
33	PGA309EVM-USB Software: Create Model Dialog with Model ID Active	43
34	PGA309EVM-USB Software: Create Model Dialog with Save File Active	44
35	PGA309EVM-USB Software: Create Pre-Cal File Dialog with Sensor Emulator Control Tool	45
36	PGA309EVM-USB Software: Create Sensor Emulator File	47
37	PGA309EVM-USB Software: Create Sensor Emulator File with Additional Tabs	48
38	PGA309EVM-USB Software: Create Sensor Emulator File by Entering Raw Bridge Sensor Data	49
39	PGA309EVM-USB Software: Create Sensor Emulator File by Entering Temperature Data	50
40	PGA309EVM-USB Software: Save a Created Sensor Emulator File	51

List of Tables

1	PGA309 Test Board Parts List	12
2	J1 Pinout (25-Pin Male DSUB)	14
3	J2 Pinout (25-Pin Female DSUB)	15
4	PGA309_Test_Board Jumper Functions: General	22
5	PGA309_Test_Board Jumper Functions: Miscellaneous Connections	23
6	PGA309_Test_Board Jumper Functions: Sensor Emulator Section	23
7	USB-DAQ-Platform Jumper Settings	24
8	Create Pre-Cal File Field Descriptions	46

1 Introduction and Overview

This document provides the information needed to set up and operate the PGA309EVM-USB evaluation module, a test platform for the [PGA309](#) programmable sensor conditioner. For a more detailed description of the PGA309, refer to the product data sheet ([SBOS292](#)) available from the Texas Instruments web site at <http://www.ti.com>. Additional support documents are listed in the section of this guide entitled [Related Documentation from Texas Instruments](#).

The PGA309EVM-USB is an evaluation module that is used to fully evaluate the PGA309. The PGA309 is an integrated circuit that provides temperature compensation and linearization for bridge sensors. The PGA309EVM-USB consists of two PCBs. One board (the USB-DAQ-Platform) generates the digital signals required to communicate with the PGA309. The other board (the PGA309_Test_Board) contains the PGA309 device, as well as support and configuration circuitry.

Throughout this document, the abbreviation *EVM* and the term *evaluation module* are synonymous with the PGA309EVM-USB.

1.1 PGA309EVM-USB Hardware

Figure 1 shows the hardware included with the PGA309EVM-USB kit. Contact the factory if any component is missing. It is highly recommended that you check the TI web site (at <http://www.ti.com>) to verify that you have the latest software. It is also recommended that you refer to the [PGA309 User's Guide](#) if you have questions about the PGA309 device itself.

The complete kit includes the following items:

- PGA309_Test_Board
- USB DAQ Platform Board
- USB cable
- Power Cable

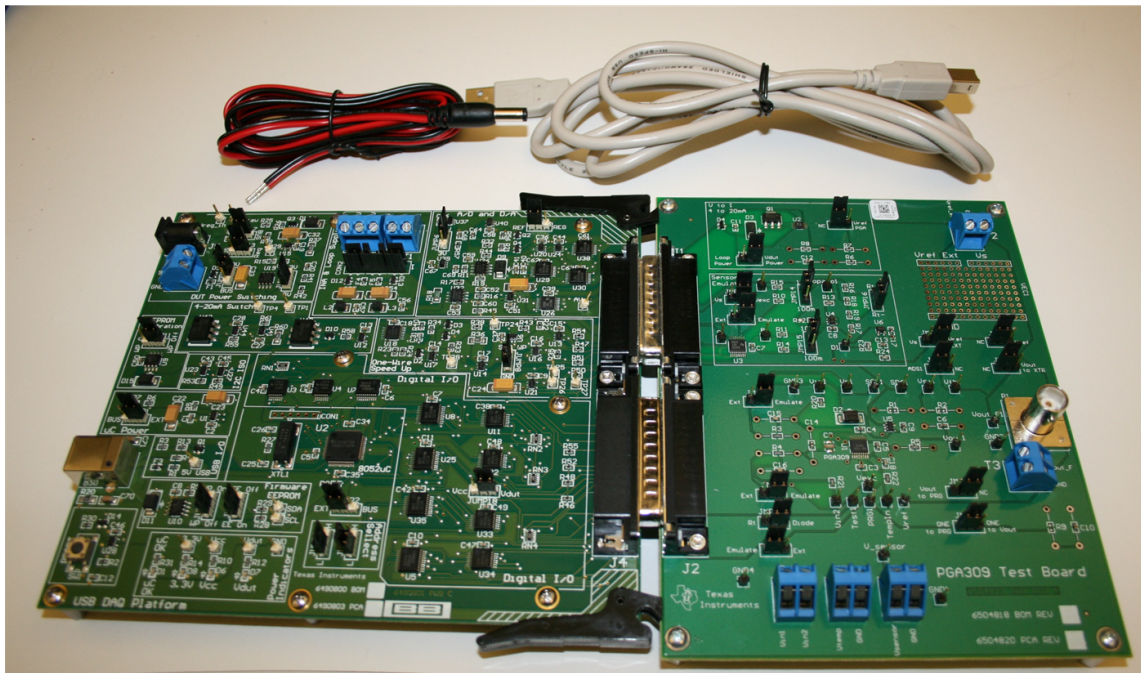

Figure 1. Hardware Included with the PGA309EVM-USB

1.2 Related Documentation from Texas Instruments

The following documents provides information regarding Texas Instruments integrated circuits used in the assembly of the PGA309EVM-USB. This user's guide is available from the TI web site under literature number [SBOU084](#). Any letter appended to the literature number corresponds to the document revision that is current at the time of the writing of this document. Newer revisions may be available from the TI web site at <http://www.ti.com>, or call the Texas Instruments Literature Response Center at (800) 477-8924 or the Product Information Center at (972) 644-5580. When ordering, identify the document by both title and literature number.

Document	Literature Number
PGA309	SBOS292
USB DAQ Platform Users Guide	SBOU056
PGA309 Users Guide	SBOU024
OPA333 Product Data Sheet	SBOS351
DAC8555 Product Data Sheet	SLAS475
XTR117 Product Data Sheet	SBOS344
PGA309EVM-USB Schematic	SBOR010
Sensor-Emulator EVM Reference Guide	SBOA102

1.3 If You Need Assistance

If you have questions about the PGA309EVM-USB evaluation module, send an e-mail to the Linear Application Team at precisionamps@list.ti.com. Include *PGA309EVM-USB* as the subject heading.

1.4 Information About Cautions and Warnings

This document contains caution statements.

CAUTION

This is an example of a caution statement. A caution statement describes a situation that could potentially damage your software or equipment.

2 System Setup

Figure 2 shows the system setup for the PGA309EVM. The PC runs software that communicates with the USB-DAQ-Platform. The USB-DAQ-Platform generates the digital signals used to communicate with the PGA309_Test_Board. Connectors on the PGA309_Test_Board allow for connection to the bridge sensor.

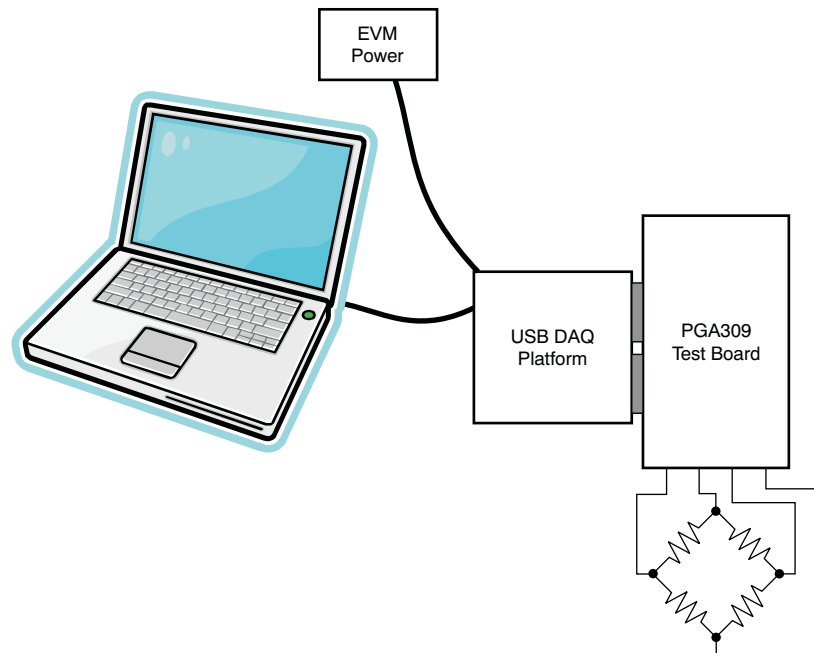

Figure 2. PGA309EVM-USB Hardware Setup

2.1 Theory of Operation for PGA309_Test_Board Hardware

Figure 3 shows the block diagram of the PGA309_Test_Board. The PGA309_Test_Board provides connections to the I²C, one-wire, analog-to-digital converters (ADCs) and digital-to-analog converters (DACs) on the USB-DAQ-Platform. It also provides connection points for external connection of the bridge sensor. The PGA309_Test_Board has circuitry to convert the PGA309 voltage output to 4mA to 20mA current.

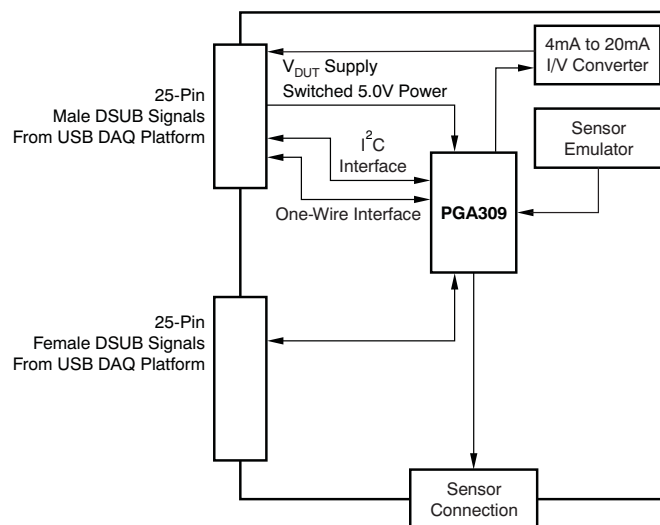

Figure 3. PGA309_Test_Board Block Diagram

The PGA309_Test_Board also has an onboard sensor emulator. The sensor emulator is a circuit that generates the same type of signals generated by a bridge sensor. The sensor emulator circuit is controlled by the PGA309EVM-USB software. Using the sensor emulator allows you to get a deeper understanding of the PGA309EVM-USB software and hardware more quickly. When the capabilities and functions of the PGA309EVM-USB are fully understood, you can connect the real-world sensor to the EVM and perform a full calibration.

Note that calibrations with real-world sensors are time-consuming because devices such as these are normally calibrated at multiple temperatures in an environmental chamber. It is not unusual for temperature calibration to require 12 hours.

2.2 PGA309_Test_Board Connections

See [Figure 4](#) for the input connections on the PGA309_Test_Board schematic. T1 provides the power connection for an external bridge sensor. T4 allows connections to each input of the external bridge sensor. T5 allows connection of the external temperature sensor. JMP7, JMP4, JMP5, and JMP6 allow users to select either the onboard sensor emulator or an external sensor. JMP12 allows users to choose between V_S or V_{EXC} for the sensor power.

The input is filtered with R3, R4, C14, C15, and C16. Note that C14 is ten times larger than C15, and C16 is used for good ac common-mode rejection. The cutoff frequency of this filter is 40.6Hz ($f = 1/(2 \pi R3 C14)$). This input filter is recommended in your final design if you have available board space.

V_{EXC} has a 100pF capacitor and TEMPIn has a 1nF capacitor. These components are also recommended in your final design.

Refer to [Figure 5](#) to see the power, reference, and digital connections on the PGA309_Test_Board schematic. T2 provides a connection for an external reference voltage. JMP1 and JMP2 allow users to select between the internal reference, an external reference, or power-supply reference. JMP7 and JMP8 allows users to connect the One-Wire signal to the PRG pin directly or through V_{OUT} .

D2 is a transient voltage suppressor. It is useful in helping to prevent damage in an electrical overstress (EOS) condition. R5 is useful in preventing EOS damage to the output. C6 filters noise at the output. C5 filters the reference output. These components are recommended for your design if PCB space permits. C4 is a decoupling capacitor; it is required in the final design.

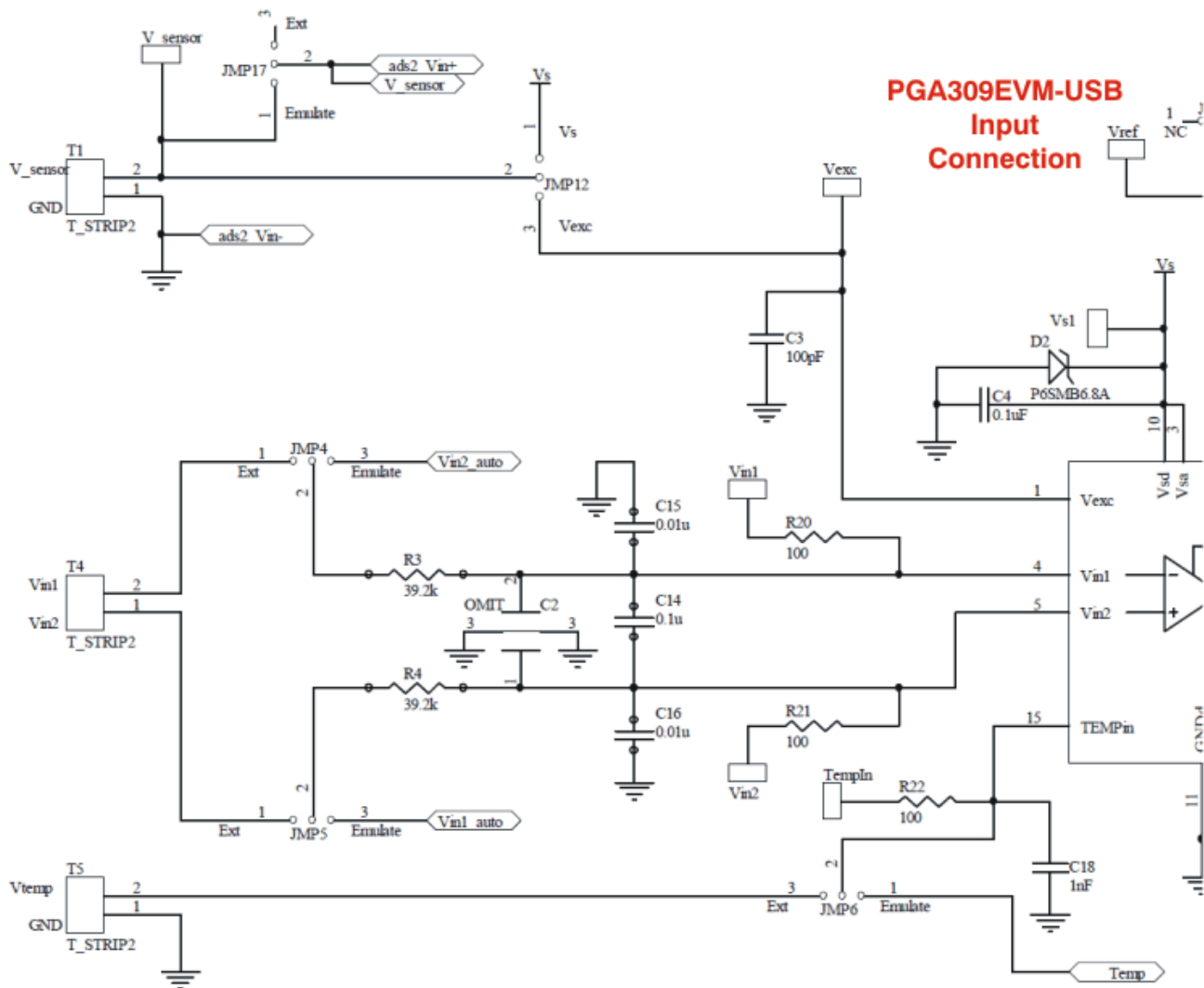

Figure 4. PGA309_Test_Board Schematic: Input Circuitry

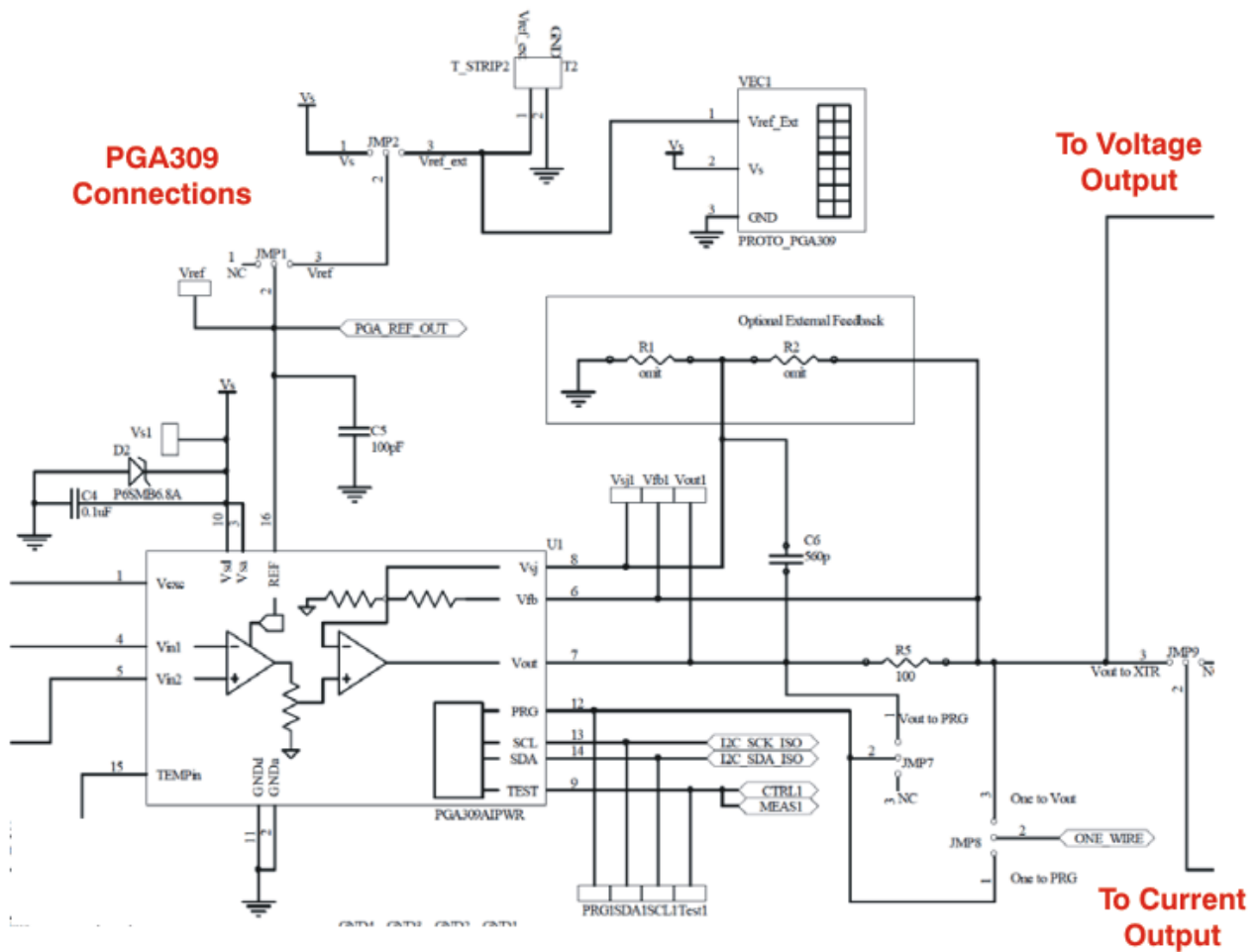

Figure 5. PGA309_Test_Board Schematic: Power, Reference, and Digital Connections

Figure 6 shows the output section of the PGA309EVM_Test_Board. There are two output options: voltage output and current output. The voltage output option is selected by placing JMP9 in the NC position. The current output option is selected by moving JMP9 to the V_{OUT} to XTR position.

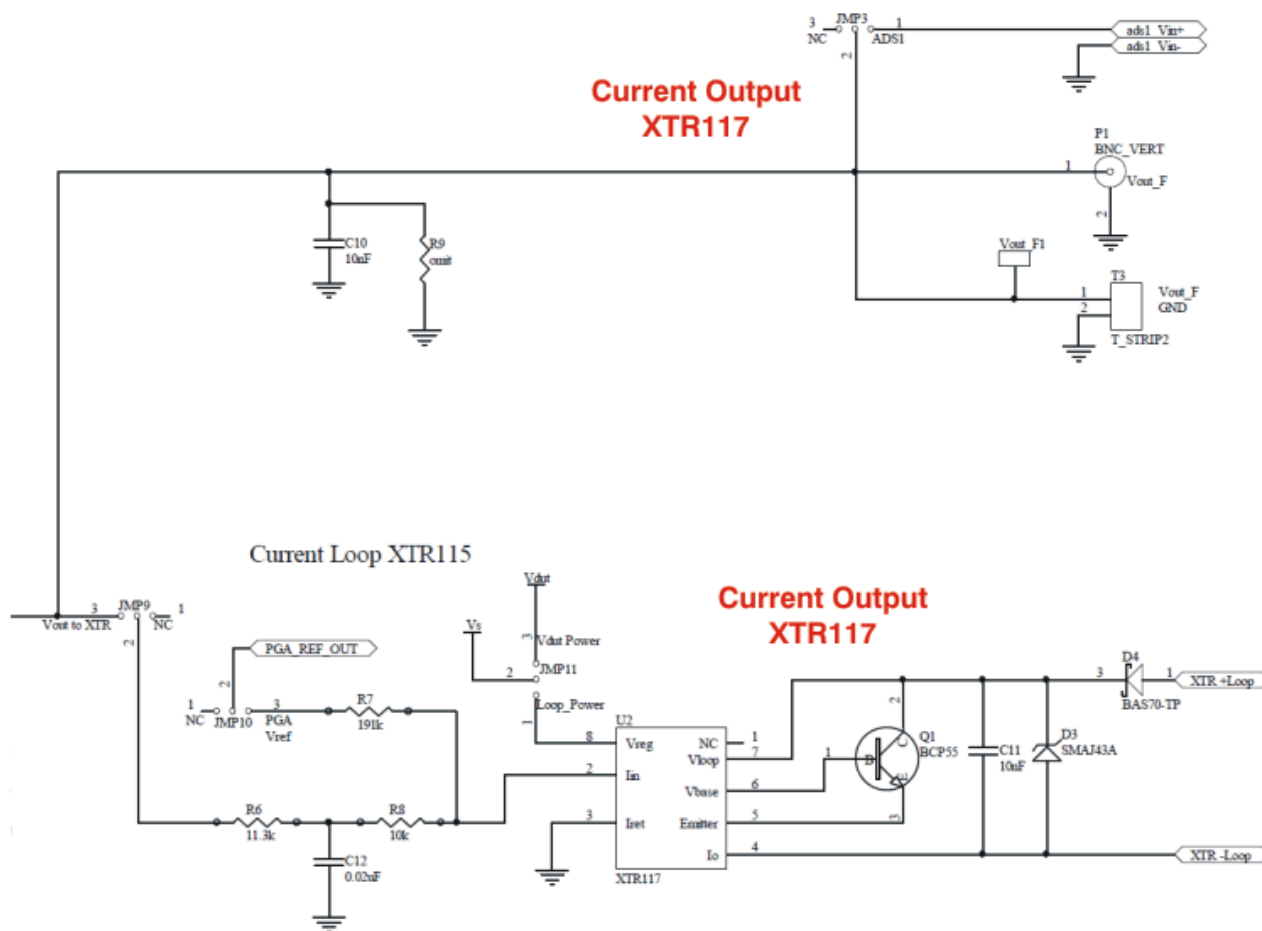

Figure 6. PGA309_Test_Board Schematic: Output Circuitry

In voltage output mode, C10 = 10nF is connected to the PGA309 output. This capacitor is used for radio frequency interference (RFI) and electromagnetic interference (EMI) immunity. This component should be included in your design, if possible.

In current output mode, the PGA309 output is connected to a voltage-to-current (V-I) converter (XTR117). The sum of R6 and R8 convert the output voltage from the PGA309 to an input current for the XTR117. R7 can be used to create an input offset current using the reference. The total input current is $I_{IN} = V_{OUT} / (R6 + R8) + V_{REF}/R7$. The output current is equal to the input current times the current gain (x 100).

D4 is used for reverse polarity protection. D3 is used for over-voltage transient protection. D3 was selected for low leakage. Leakage on D3 directly contributes to error. C11 is a decoupling capacitor and is required for proper operation. The external transistor, Q1, conducts the majority of the full-scale output current. Power dissipation in this transistor can approach 0.8W with high loop voltage (40V) and 20mA output current.

Figure 7 shows the sensor emulator circuit. The sensor emulator generates signals to help users evaluate the PGA309. No part of this circuit is required in your final design. The sensor emulator uses a DAC8555 (U8) to generate an emulated temperature signal, common-mode signal, and differential signal. These signals can be controlled using software to produce levels that closely match real-world sensors.

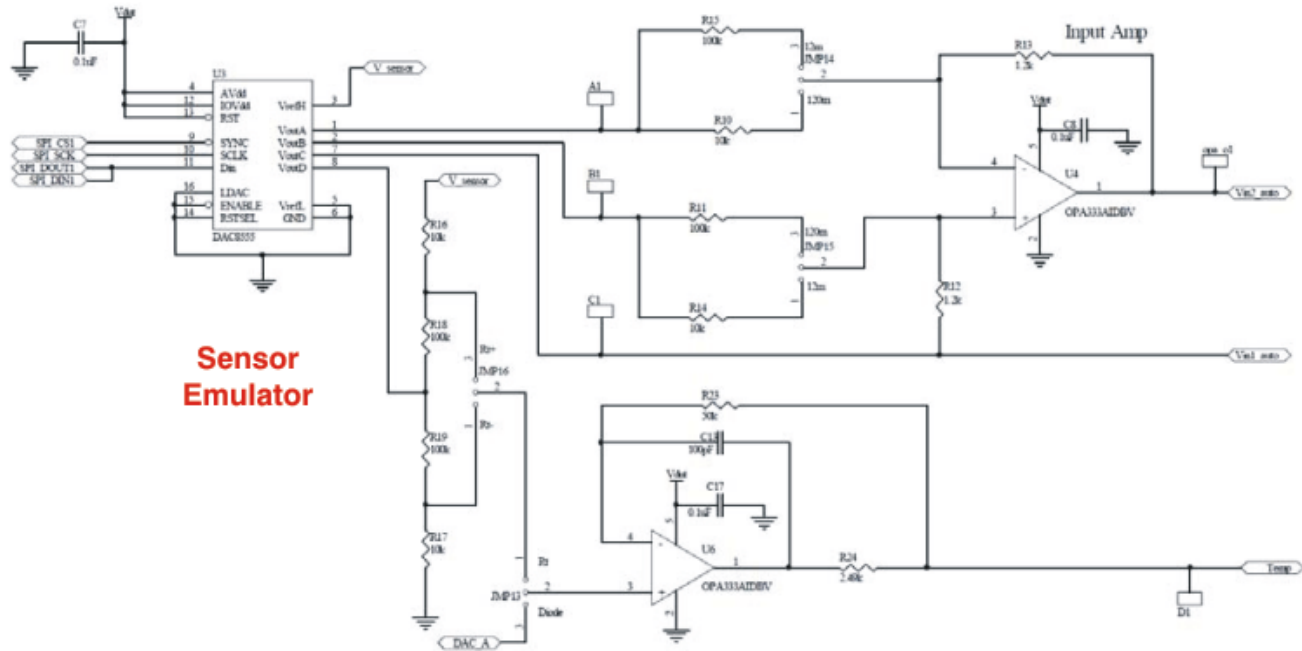

Figure 7. PGA309_Test_Board Schematic: Sensor Emulator Circuitry

The operational amplifier U4 and associated resistors is a differential amplifier with jumper selectable attenuation. The possible attenuations are 0.12 and 0.012. The attenuation produces a more accurate and stable emulated sensor output. For example, when the DAC outputs 3V, the sensor emulator outputs $3V \times 0.012 = 36mV$ (assuming that attenuation is set in the 0.012 position). Thus, the maximum output of the sensor emulator is 120mV/V and 12mV/V.

The op amp U6 buffers the emulated temperature signal. Resistors R16, R17, R18, and R19 are used to attenuate the DAC output for temperature emulation and to reference the temperature signal to supply or ground. JMP13 allows the resistor network to be bypassed for direct connection to the DAC (diode temperature sensor mode).

Figure 8 illustrates the two 25-pin D-SUB connectors J1 and J2. These connectors provide all the signals necessary to communicate with the PGA309. U5 is the EEPROM used to store the calibration look-up table used with the PGA309.

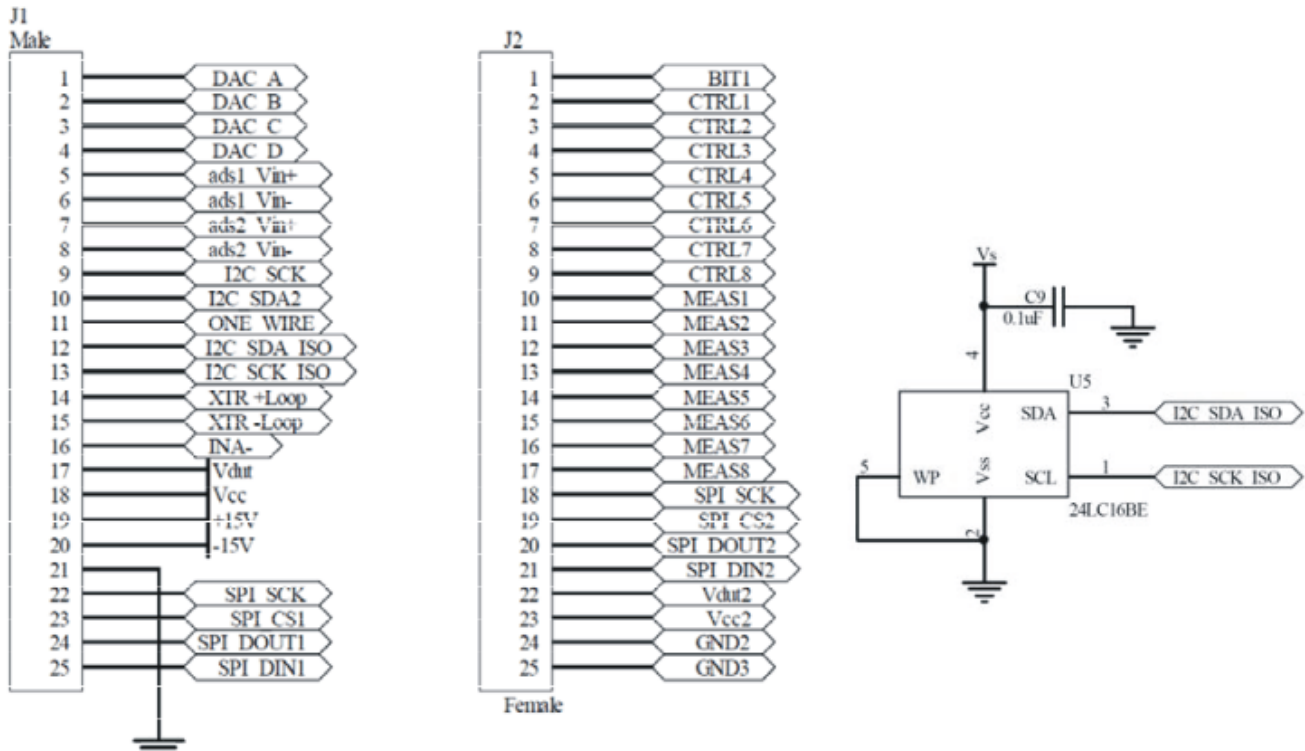

Figure 8. PGA309_Test_Board Connections to USB-DAQ-Platform and EEPROM

2.3 PGA309_Test_Board Parts List

Table 1 describes the parts list for the PGA309_Test_Board.

Table 1. PGA309 Test Board Parts List

Qty	Value	Ref Des	Description	Vendor	Part Number
1	560pF	C6	Capacitor, ceramic 560pF 50V NP0 0603	Panasonic - ECG	ECJ-1VC1H561J
3	100pF	C3 C5, C13	Capacitor, ceramic 560pF 50V NP0 0603		ECJ-1VC2A101J
6	0.1µF	C4, C7, C8, C9, C14, C17	Capacitor, 0.1µF 25V, ceramic Y5V 0603	Kemet	CC0603ZRY5V8BB104
2	.01µF	C15, C16	Capacitor, ceramic .01µF 10% 100V X7R 0603	AVX	06031C103KAT2A
1	1nF	C18	Capacitor, 1000pF, 100V, ceramic X7R 0603	Panasonic - ECG	ECJ-1VB2A102K
2	10nF	C10, C11	Capacitor, 10000pF, 50V, ceramic X7R 0603	Kemet	C0603C103K5RACTU
1	0.02µF	C12	Capacitor, ceramic 22000pF, 100V X7R 10%0603	TDK Corporation	C1608X7R2A223K
1	1000pF	C2	Omit; not installed	JOHANSON DIELECTRICS	501R18W102KV4E
4	100kΩ	R11, R15, R18, R19	Resistor, 100kΩ 1/6W 0.1% 0603 SMD	Susumu Co Ltd	RGH1608-2C-P-104-B
2	1.2kΩ	R12, R13	Resistor, 1.2kΩ 1/6W 0.1% 0603 SMD	Susumu Co Ltd	RGH1608-2C-P-122-B
5	10kΩ	R8, R10, R14, R16, R17	Resistor, 10.0kΩ 1/6W 0.1% 0603 SMD	Susumu Co Ltd	RGH1608-2C-P-103-B
4	100Ω	R5, R20, R21, R22	Resistor, 100kΩ 1/10W 1% 0603 SMD	Yageo Corporation	RC0603FR-07100RL
1	191kΩ	R7	Resistor, 191kΩ 1/10W 1% 0603 SMD	Yageo Corporation	ERJ-3EKF1913V
1	11.3kΩ	R6	Resistor, 11.3kΩ 1/10W 1% 0603 SMD	Yageo Corporation	ERJ-3EKF1132V
2	39.2kΩ	R3, R4	Resistor, 39.2kΩ 1/10W 1% 0603 SMD	Yageo Corporation	RC0603FR-0739K2L
1	50kΩ	R23	Resistor, 49.9kΩ 1/16W .5% 0603 SMD	Sunsuma	RR0816P-4992-D-68C
1	2.49kΩ	R24	Resistor, 2.49kΩ 1/16W .5% 0603 SMD	Sunsuma	RR0816P-2491-D-39H
0	omit	R1, R2, R9	Omit; not installed		
1	PGA309	U1	Smart Programmable Sensor	Texas Instruments	PGA309AIPWT
1	BNC	P1	Connector, Jack BNC Vertical 50Ω PCB	Tyco Electronics/Amp	5227699-1
2	OPA333AID BVT	U4 U6	IC Op Amp 1.8V 0-DRIFT SOT23-5	Texas Instruments	OPA333AIDBVT
1	DAC8555	U3	IC DAC 16BIT QUAD 16-TSSOP	Texas Instruments	DAC8555IPW
1	24LC16BT	U5	IC SRL EEPROM 16K 2.5V SOT23-5	Microchip Technology	24LC16BT-I/OT
1	XTR117	U2	IC 4mA-20mA Current-Loop TX 8-MSOP	Texas Instruments	XTR117AIDGKT
1	6.8V transzorb	D2	TVS Zener Unidirectional 600W 6.8V SMB	ON Semiconductor	P6SMB6.8AT3G
1	SMAJ43A	D3	TVS 400W 43V Unidirectional SMA	Micro Commercial Components	SMAJ43A-TP
1	BAS70TP	D4	Diode, Schottky 70V 200mA SOT23	Micro Commercial Components	BAS70TPMSCT-ND
1	NPN	Q1	IC, Transistor NPN SS GP 1.5A SOT223-4	Fairchild Semiconductor	BCP55
5	ED300/2	T1, T2, T3, T4, T5	2-Position Terminal Strip, Cage Clamp, 45°, 15A, Dove-tailed	On-Shore Technology Inc	ED300/2

Table 1. PGA309 Test Board Parts List (continued)

Qty	Value	Ref Des	Description	Vendor	Part Number
17	JUMP2 Cut to Size	JMP1, JMP2, JMP3, JMP4, JMP5, JMP6, JMP7, JMP8, JMP9, JMP10, JMP11, JMP12, JMP13, JMP14, JMP15, JMP16, JMP17,	Terminal strip, 3-position, .100 centers, .025 square pins	Samtec	TSW-103-07-G-S
24	TP Cut to Size	V_Sensor, OPA_O1, C1, B1, A, 1 TempIn, GND1, D1, GND2, V _{EXC} , V _{REF} , V _{OUT_F1} , V _{IN2} , PRG1, V _{OUT1} , V _{FB1} , V _{S1} , SCL1, V _{SJ1} , GND4, V _{IN1} , SDA1, GND3, Test1,	Terminal strip, 1-position, .100 centers, .025 square pins	Samtec	TSW-101-07-G-S
17	Jumper Shunts	JMP1, JMP2, JMP3, JMP4, JMP5, JMP6, JMP7, JMP8, JMP9, JMP10, JMP11, JMP12, JMP13, JMP14, JMP15, JMP16, JMP17,	Shunt LP w/Handle 2-position, 30AU	Tyco Electronics Amp	881545-2
1	DSUB25M	J1	Connector, D-SUB PLUG R/A 25POS 30GOLD (with Threaded Inserts and Board locks)	AMP/Tyco Electronics	5747842-4
1	DSUB25F	J2	Connector, D-SUB RCPT R/A 25POS 30GOLD (with Threaded Inserts and Board locks)	AMP/Tyco Electronics	5747846-4
4	Standoffs		Standoffs, Hex , 4-40 Threaded, 0.500" length, 0.250" OD, Aluminum Iridite Finish	Keystone	2203
4	Screws		Machine Screw, 4-40x3/8" Phillips PanHead, Steel, Zinc Plated	Building Fasteners	PMS 440 0038 PH

2.4 PGA309_Test_Board: Signal Definitions and Pinouts

This section provides the signal definitions for the PGA309_Test_Board.

2.4.1 J1 (25-Pin Male DSUB)

Table 2 shows the different signals connected to J1 on the PGA309_Test_Board. This table also identifies signals connected to pins on J1 that are not used on the PGA309_Test_Board.

Table 2. J1 Pinout (25-Pin Male DSUB)

Pin on J1	Signal	Used on This EVM	PGA309 Pin
1	DAC A	No	
2	DAC B	No	
3	DAC C	No	
4	DAC D	No	
5	ADS1+	No	
6	ADS1-	No	
7	ADS2+	No	
8	ADS2-	No	
9	I2C_SCK	No	
10	I2C_SDA2	No	
11	ONE_WIRE	No	
12	I2C_SCK_ISO	Yes	SCL
13	I2C_SDA_ISO	Yes	SDA
14	XTR_LOOP+	No	
15	XTR_LOOP-	No	
16	INA-	No	
17	V _{DUT}	Yes	V _S
18	V _{CC}	No	
19	+15v	No	
20	-15v	No	
21	GND	Yes	GND
22	SPI_SCK	No	
23	SPI_CS1	No	
24	SPI_DOUT	No	
25	SPI_DIN1	No	

2.4.2 J2 (25-Pin Female DSUB)

Table 3 shows the different signals connected to J2 on the PGA309_Test_Board. This table also identifies signals connected to pins on J2 that are not used on PGA309_Test_Board.

Table 3. J2 Pinout (25-Pin Female DSUB)

Pin on J2	Signal	Used on This EVM	PGA309 Pin
1	NC	No	
2	CTRL1	Yes	Convert
3	CTRL2	Yes	GPIO
4	CTRL3	No	
5	CTRL4	No	
6	CTRL5	No	
7	CTRL6	No	
8	CTRL7	No	
9	CTRL8	No	
10	MEAS1	Yes	Warning
11	MEAS2	Yes	GPIO
12	MEAS3	Yes	Overlimit
13	MEAS4	Yes	Critical
14	MEAS5	Yes	ALT
15	MEAS6	No	
16	MEAS7	No	
17	MEAS8	No	
18	SPI_SCK	No	
19	SPI_CS2	No	
20	SPI_DOUT2	No	
21	SPI_DIN2	No	
22	V _{DUT}	No	V _s
23	V _{CC}	No	
24	GND	Yes	GND
25	GND	Yes	GND

2.5 Theory of Operation for USB-DAQ-Platform

Figure 9 shows the block diagram for the USB-DAQ-Platform. This platform is a general-purpose data acquisition system that is used on several different Texas Instruments evaluation modules. The details of its operation are included in a separate document (available for download at www.ti.com). The block diagram shown in Figure 9 gives a brief overview of the platform. The primary control device on the USB-DAQ-Platform is the TUSB3210.

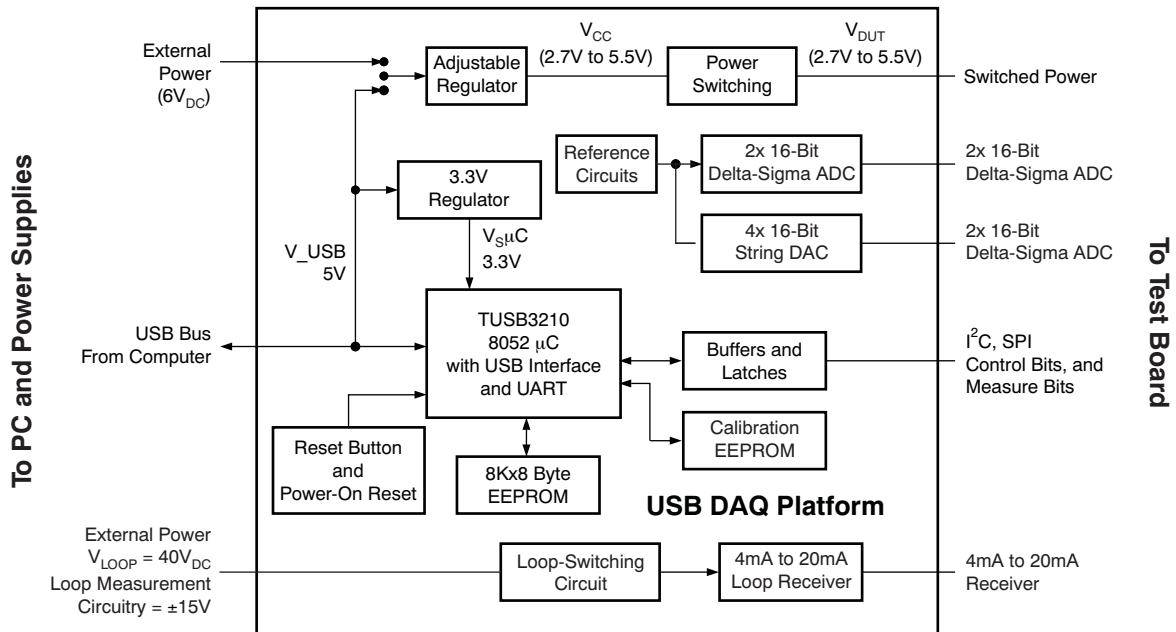

Figure 9. Theory of Operation For USB-DAQ-Platform

3 PGA309EVM-USB Hardware Setup

The PGA309EVM-USB Hardware setup involves connecting the two halves of the EVM together, applying power, connecting the USB cable, and setting the jumpers. This section covers the details of this procedure.

3.1 Electrostatic Discharge Warning

Many of the components on the PBA309EVM-USB are susceptible to damage by electrostatic discharge (ESD). Customers are advised to observe proper ESD handling precautions when unpacking and handling the EVM, including the use of a grounded wrist strap at an approved ESD workstation.

CAUTION

Failure to observe ESD handling procedures may result in damage to EVM components.

3.2 Typical Hardware Connections

To set up the PGA309EVM-USB hardware, connect the two halves of the EVM together, apply power, and then connect the external sensor. Figure 10 shows the typical hardware connections.

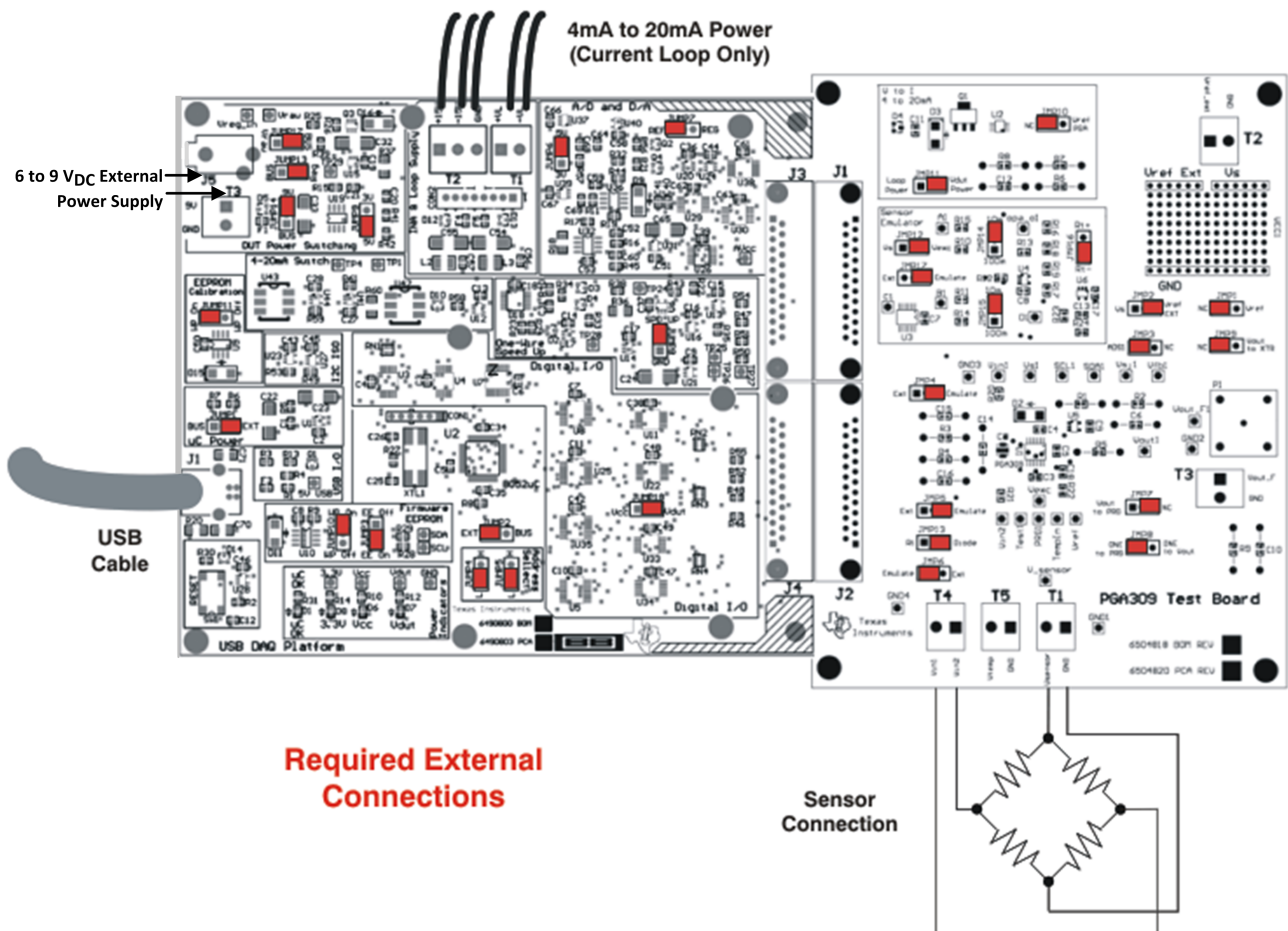

Figure 10. PGA309EVM-USB Typical Hardware Connections

3.3 Connecting the Hardware

To connect the two PCBs of the PGA309EVM-USB together, gently push on both sides of the D-SUB connectors (as shown in [Figure 11](#)). Make sure that the two connectors are completely pushed together; that is, loose connections may cause intermittent operation.

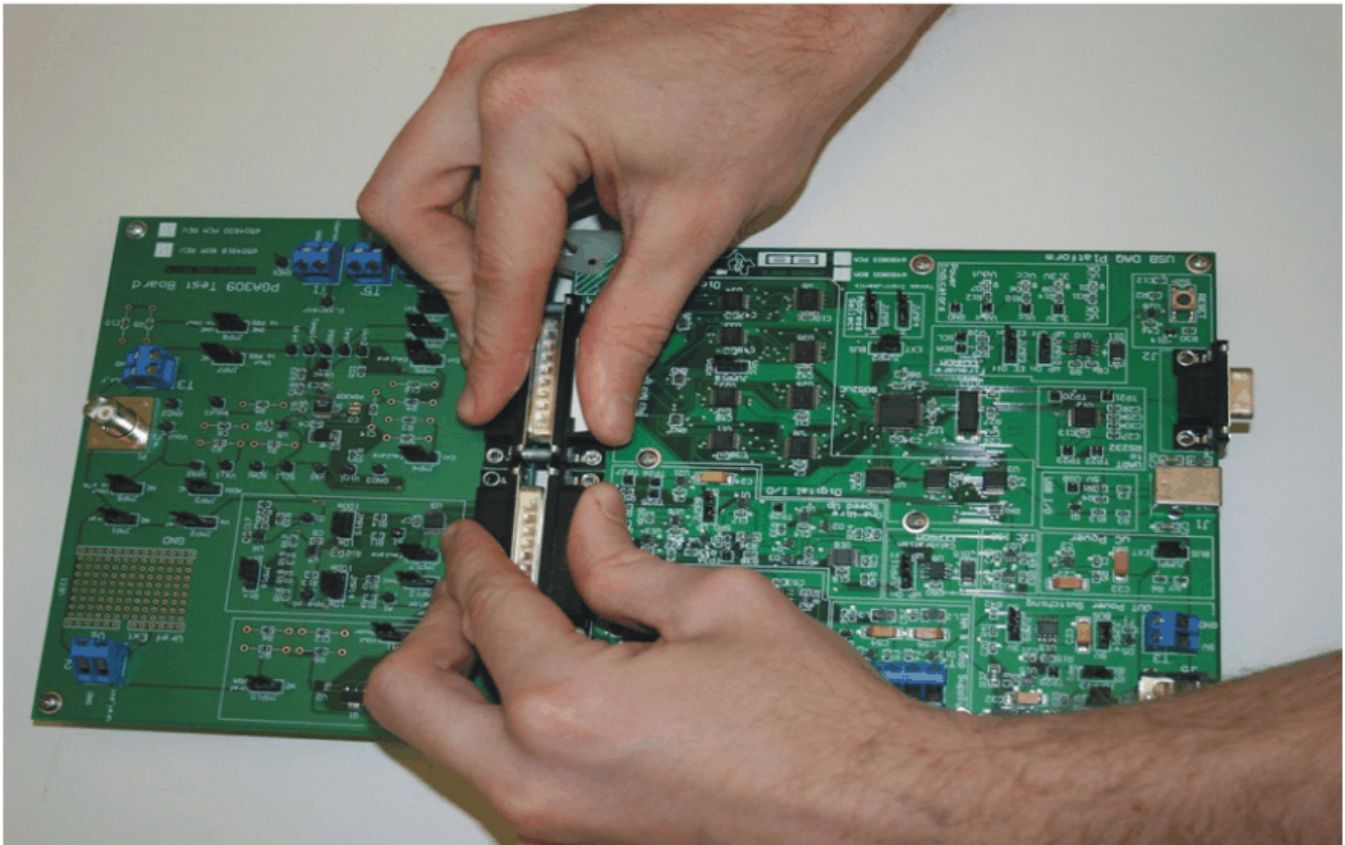

Figure 11. Connecting the Two EVM PCBs

3.4 Connecting Power

After the two parts of the PGA309EVM-USB are connected, as shown in [Figure 12](#), connect the power to the EVM. Always connect power before connecting the USB cable. If you connect the USB cable before connecting the power, the computer will attempt to communicate with an unpowered device that will not be able to respond.

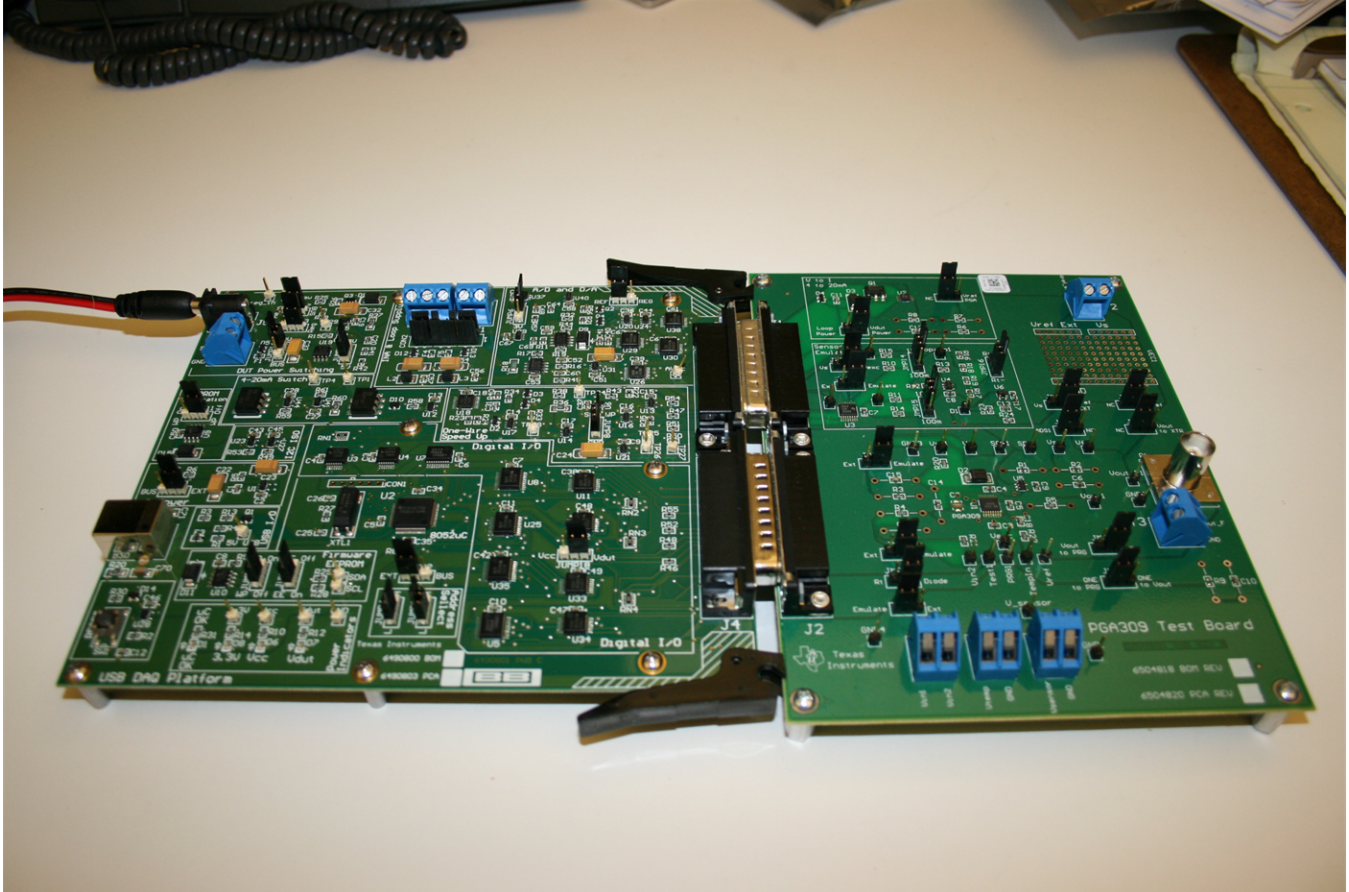

Figure 12. Connecting Power to the EVM

3.5 Connecting the USB Cable to the PGA309EVM-USB

Figure 13 shows the typical response to connecting the USB-DAQ-Platform to a PC USB port for the first time. Note that the EVM must be powered on before connecting the USB cable. Typically, the computer will respond with a *Found New Hardware, USB Device* pop-up. The pop-up typically changes to *Found New Hardware, USB Human Interface Device*. This pop-up indicates that the device is ready to be used. The USB DAQ platform uses the *Human Interface Device Drivers* that are part of the Microsoft® Windows® operating system.

In some cases, the Windows *Add Hardware Wizard* will pop up. If this prompt occurs, allow the system device manager to install the *Human Interface Drivers* by clicking **Yes** when requested to install drivers.

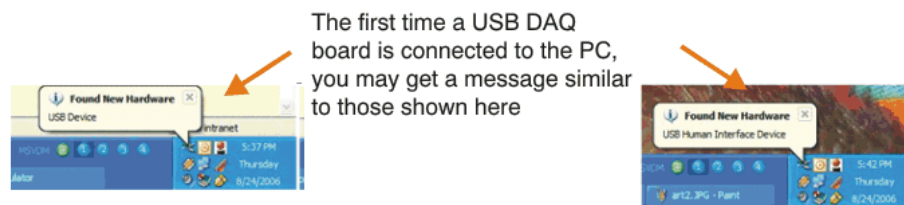
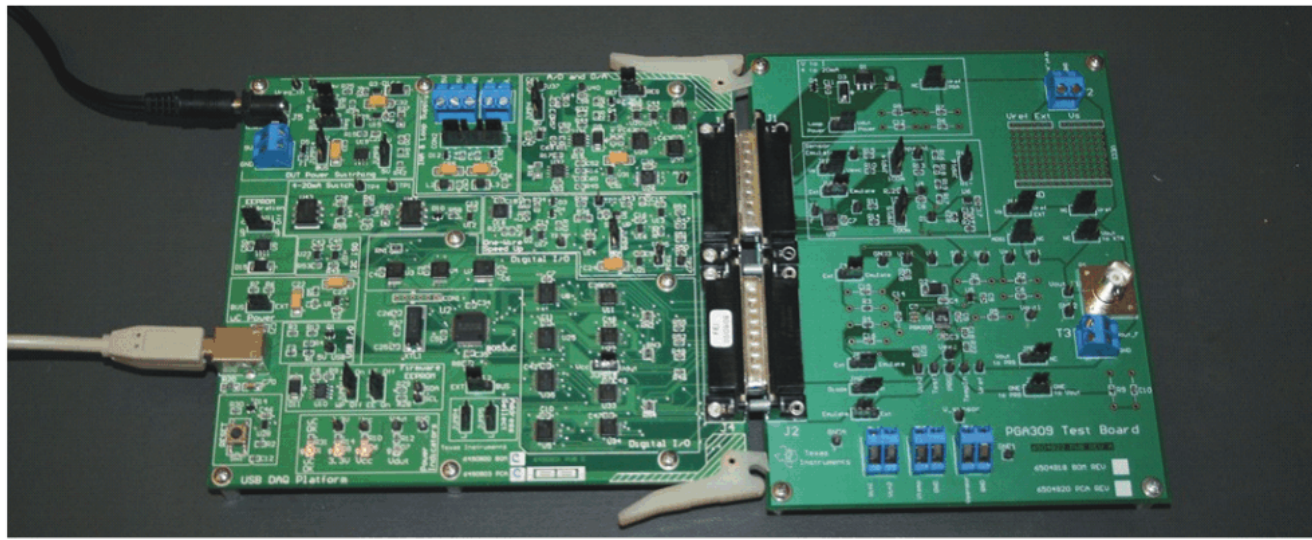

Figure 13. Connecting the USB Cable

3.6 PGA309EVM-USB Jumper Settings

Figure 14 illustrates the default jumpers configuration for the PGA309_Test_Board. In general, the jumper settings of the USB-DAQ-Platform do not need to be changed. You may want to change some of the jumpers on the PGA309_Test_Board to match your specific sensor conditioning design.

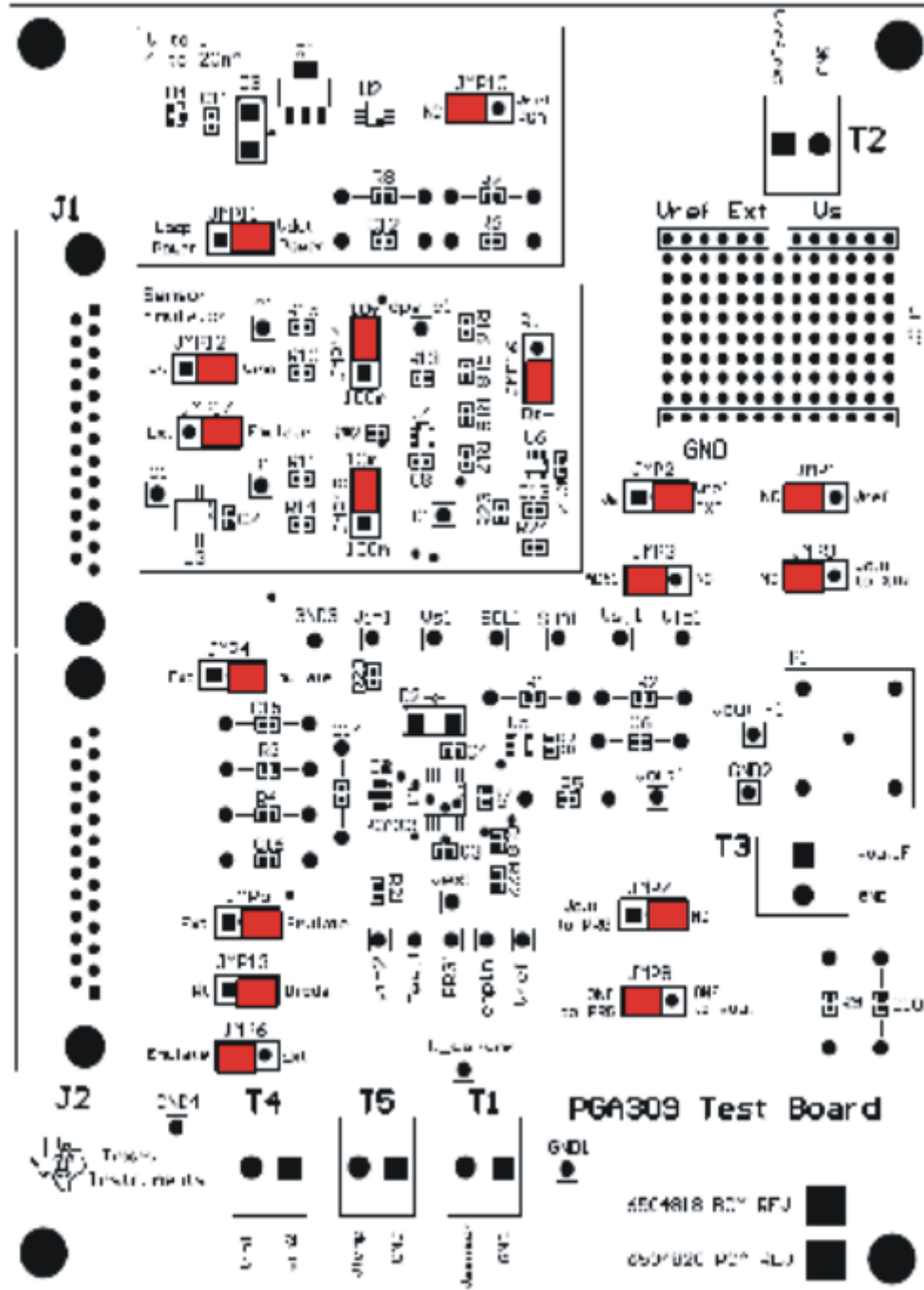

Figure 14. Default Jumper Settings (PGA309_Test_Board)

Figure 15 shows the default jumpers configuration for the USB-DAQ-Platform. In general, the jumper settings of the USB-DAQ-Platform do not need to be changed.

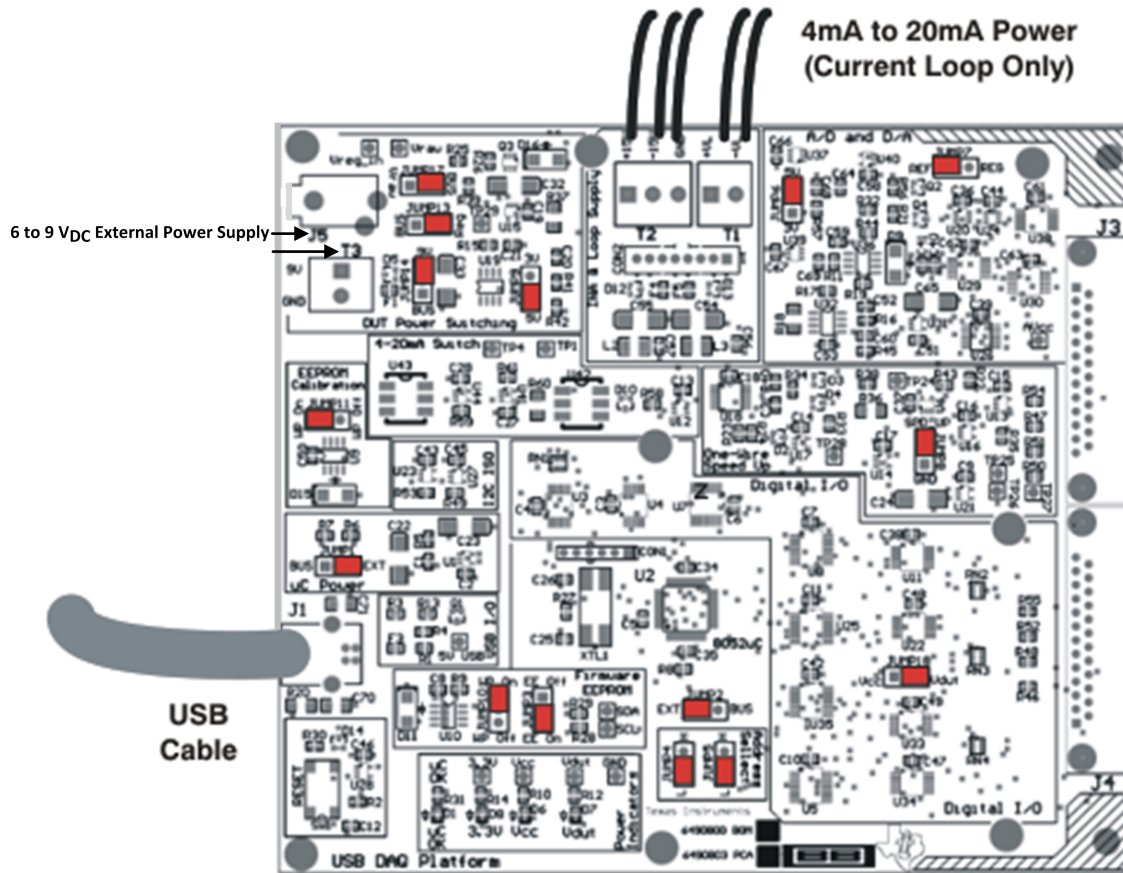

Figure 15. Default Jumper Settings (USB-DAQ-Platform)

Table 4 explains the function of the jumpers on the PGA309_Test_Board.

Table 4. PGA309_Test_Board Jumper Functions: General

Jumper	Default	Purpose
JMP10	NC	This jumper is used to connect the current loop output (XTR117). For voltage output modules, set this jumper to the NC (no connect) position. For current-loop modules, set this jumper to the V_{ref} PGA position.
JMP11	V_{DUT} power	This jumper is used to connect the current-loop output (XTR117). For voltage output modules, set this jumper to the V_{dut} Power (5V connected to power) position. For current-loop modules, set this jumper to the Loop Power (power to loop supply) position.
JMP9	NC	This jumper connects the V_{OUT} pin on the PGA309 to the XTR117 input. For voltage output modules, set this jumper to the NC (no connect) position. For current-loop modules, set this jumper to the V_{out} to XTR position.

Table 5 describes the function of the jumpers in the Miscellaneous connections section of the PGA309 Test Board.

Table 5. PGA309_Test_Board Jumper Functions: Miscellaneous Connections

Jumper	Default	Purpose
JMP1, JMP2	NC	For JMP1 = NC, JMP2 = $V_{REF\ EXT}$: The REF pin on the PGA309 is configured for internal reference. In this mode, JMP2 is not connected, so its position does not matter.
	$V_{REF\ EXT}$	For JMP1 = V_{REF} , JMP2 = V_S : The REF pin is configured for external reference and is connected to V_S . For JMP1 = V_{REF} , and JMP2 = $V_{REF\ EXT}$: The REF pin is configured for external reference and is connected to T2 (terminal for external reference connection).
JMP3	ADS1	For JMP3 = ADS1, it connects the analog-to-digital converter (ADC) on the USB-DAQ-Platform to the output of the PGA309. The ADC on the USB-DAQ-Platform allows full measurement and calibration of the PGA309 without any additional instruments.
	NC	For JMP3 = NC, the ADC on the USB-DAQ-Platform is not connected to the PGA309. This mode is useful if you want to use an external DMM in place of the USB-DAQ ADC.
JMP7, JMP8	NC	For JMP7 = NC, and JMP8 = One to PRG: In this mode, the one-wire signal from the USB-DAQ-Platform is connected directly to the PRG pin on the PGA309. This mode is commonly called <i>Four-wire mode</i> because only four connections are required (Power, GND, V_{OUT} , and PRG).
	One to PRG	For JMP7 = V_{OUT} to PRG, and JMP8 = One to V_{OUT} : In this mode, the one-wire signal from the USB-DAQ-Platform is connected to the V_{OUT} /PRG pin on the PGA309. This mode is commonly called <i>Three-wire mode</i> because only three connections are required (Power, GND, and V_{OUT} /PRG).

Table 6 explains the function of the jumpers in the sensor emulator section connections section of the PGA309 Test Board.

Table 6. PGA309_Test_Board Jumper Functions: Sensor Emulator Section

Jumper	Default	Purpose
JMP12	V_{EXC}	This jumper selects V_S or V_{EXC} as the reference for the sensor emulator. Using V_S as the reference is commonly called <i>ratiometric mode</i> .
JMP17, JMP4, JMP5, JMP6	Emulate	These jumpers select the sensor emulator when in the Emulate position. When the jumper is in the EXT position, it selects the external sensor.
JMP14, JMP15	10mV	These jumpers select the range of the sensor emulator.
		This jumper is used for the sensor emulator only; its position is not important for externally-connected, real-world sensors.
		10m = maximum emulator output is 10mV/V. 100m = maximum emulator output is 100mV/V.
JMP13, JMP16	RT-, Diode	This jumper selects the type of temperature sensor you will emulate on the EVM. This jumper is used for the sensor emulator only; its position is not important for externally-connected, real-world sensors.
		JMP13 = Diode, JMP16 = RT-. In this position, the temperature sensor emulation is set for diode type temperature sensor. When JMP13 = Diode, the position of JMP16 does not matter.
		JMP13 = RT, JMP16 = RT-. In this position, the temperature sensor emulation is set for RT-.
		JMP13 = RT, JMP16 = RT+. In this position, the temperature sensor emulation is set for RT+.

Table 7 explains the function of the USB-DAQ-Platform jumpers. For most applications the default jumper position should be used. A separate document gives details regarding the operation and design of the USB-DAQ-Platform.

Table 7. USB-DAQ-Platform Jumper Settings

Jumper	Default	Purpose
JUMP1	EXT	This jumper selects external power or bus power. External power is applied on J5 or T3 (9V dc). Bus power is 5V from the USB bus. External power is typically used because the USB bus power is noisy.
JUMP2	EXT	Same as JUMP1.
JUMP3	EE ON	This jumper determines where the PGA309 gets its power supply. In the V_{DUT} position, the EVM provides power. The default is the V_{DUT} position. In the V_{S_EXT} position, the power is connected externally.
JUMP4, JUMP5	L, L	This jumper sets the address for the USB board. The only reason to change from the default is if multiple boards are being used.
JUMP9	5V	This jumper selects the voltage of the device under test supply ($V_{DUT} = 5V$ or $3V$)
JUMP10	WP ON	This jumper write-protects the firmware EEPROM.
JUMP11	WP ON	This jumper write-protects the calibration EEPROM
JUMP13	Reg	This jumper configures the regulator output to generate the V_{DUT} supply. The USB bus can be used as the V_{DUT} supply.
JUMP14	9V	This jumper configures the external power (9V as apposed to the bus)
JUMP17	BUS	While in the BUS position V_{DUT} operation is normal. While in the V_{RAW} position, the V_{DUT} supply is connected to an external source. This allows for any value of V_{DUT} between 3V and 5V.
JUMP18	V_{DUT}	Connects the pull-up resistor on GPIO to the V_{DUT} supply or the V_{CC} supply.

CAUTION

Adjusting the value of V_{DUT} beyond the range of 3V to 5V will damage the EVM.

4 PGA309EVM-USB Software Overview

This section discusses how to install and use the PGA309EVM-USB software.

4.1 Operating Systems for PGA309 Software

The PGA309EVM-USB software has been tested on the Microsoft Windows XP operating system (OS) with United States and European regional settings. The software should also function on other Windows operating systems.

4.2 PGA309EVM-USB Software Install

Follow these steps to install the PGA309EVM-USB software:

- Step 1. Software can be downloaded from the [PGA309EVM-USB web page](#), or from the disk included with the PGA309EVM-USB, which contains a folder called *Install_software/*.
- Step 2. Find the file called *setup.exe*. Double-click the file to start the installation process.
- Step 3. Follow the on-screen prompts to install the software.
- Step 4. To remove the application, use the Windows Control Panel utility, *Add/Remove Software*.

4.3 Starting the PGA309EVM-USB Software

The PGA309EVM-USB software can be operated through the Windows *Start* menu. From *Start*, select *All Programs*; then select the **PGA309EVM-USB** program. Refer to [Figure 17](#) for a screenshot of how the software should appear if the EVM is functioning properly.

4.4 Using the PGA309EVM-USB Software

The PGA309EVM-USB software has five different primary tabs that allow users to access different features of the PGA309 itself. Each tab is designed to provide an intuitive graphical interface that will help users to gain a better understanding of the device.

4.5 Block Diagram Tab

The block diagram, illustrated in Figure 16, provides full access to all the elements in the PGA309. Changes made to the block diagram are reflected in the register table. This feature is helpful when users experiment with various aspects of a particular configuration or test setup.

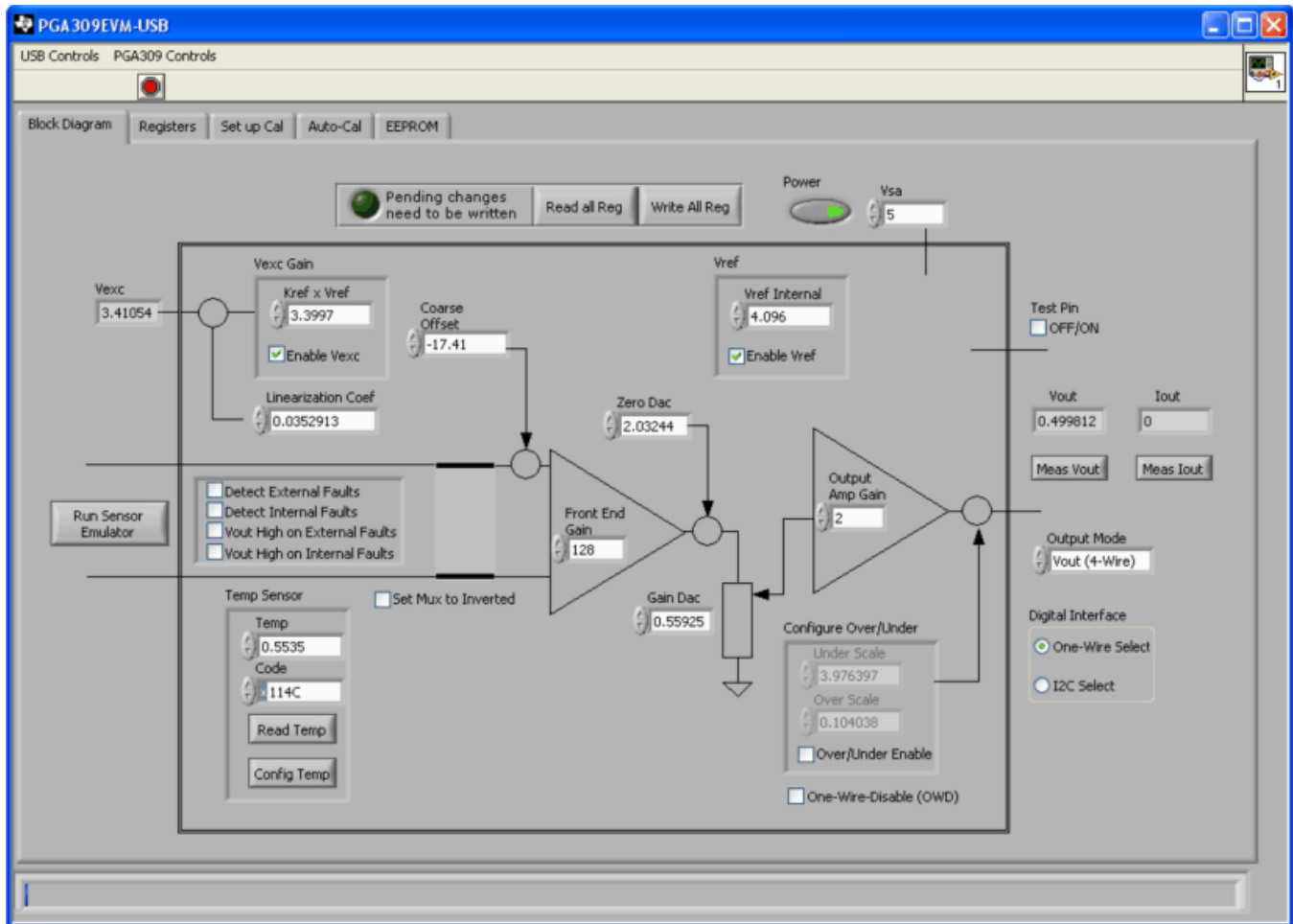

Figure 16. PGA309EVM-USB Software: Block Diagram

4.6 Registers Tab

Figure 17 illustrates the Registers tab.

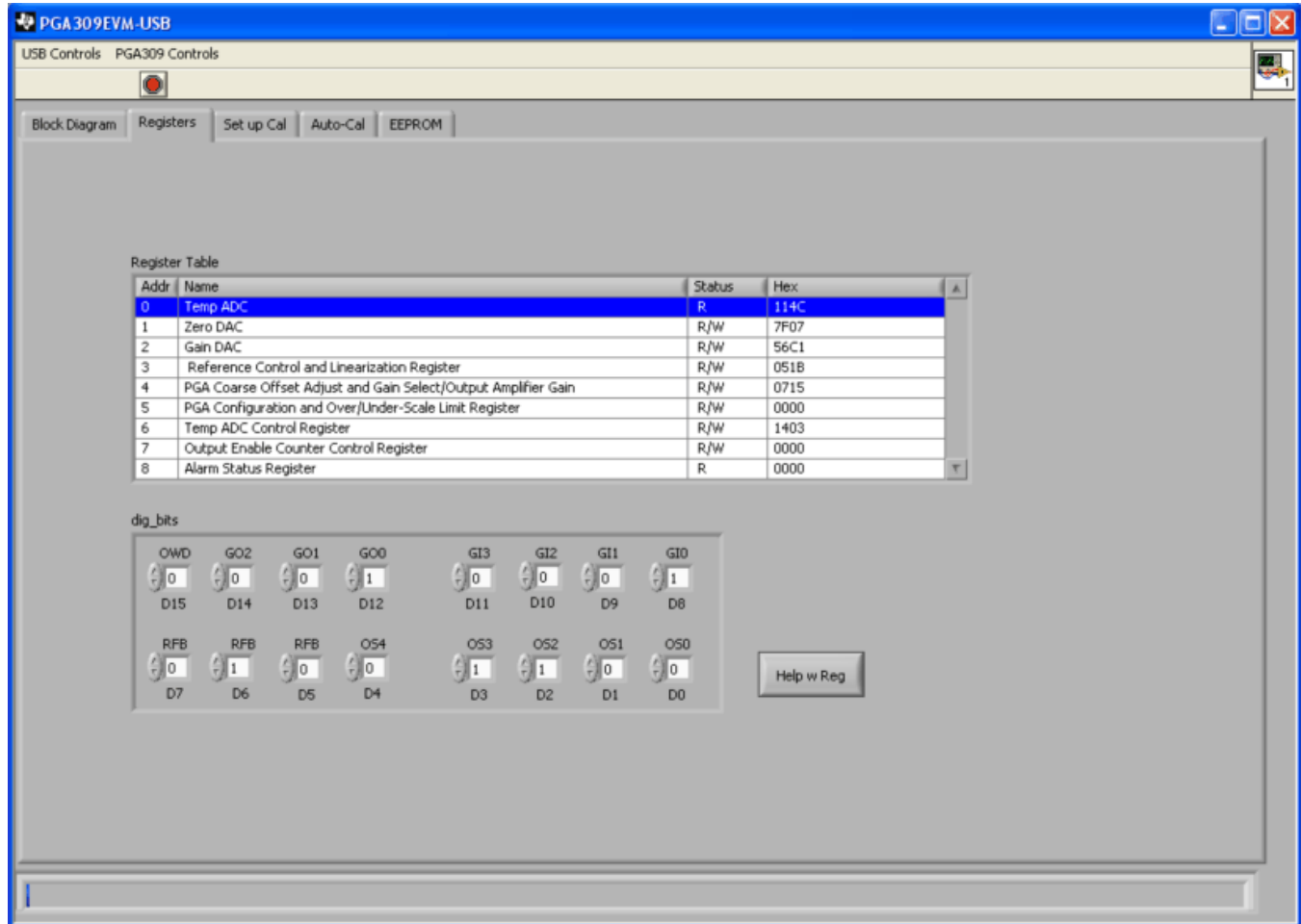

Figure 17. PGA309EVM-USB Software: Registers Tab

This tab presents a *Register Table* that shows a summary of the PGA309 device registers. You can select any row in the table by clicking on it with your mouse. When a row is selected, it is highlighted in blue in the table. The individual 16 bits in the selected register are displayed below the register table. You can edit the bit value by using the up (↑) or down (↓) arrow to the left of the bit. Any changes made to the bit are displayed in the table. Additionally, changes to the device registers initiated on other tabs in the software will also update the Registers tab.

4.7 Set-Up Cal Tab

The Set-Up Cal tab (shown in [Figure 18](#)) allows users to create and select files that determine the calibration parameters.

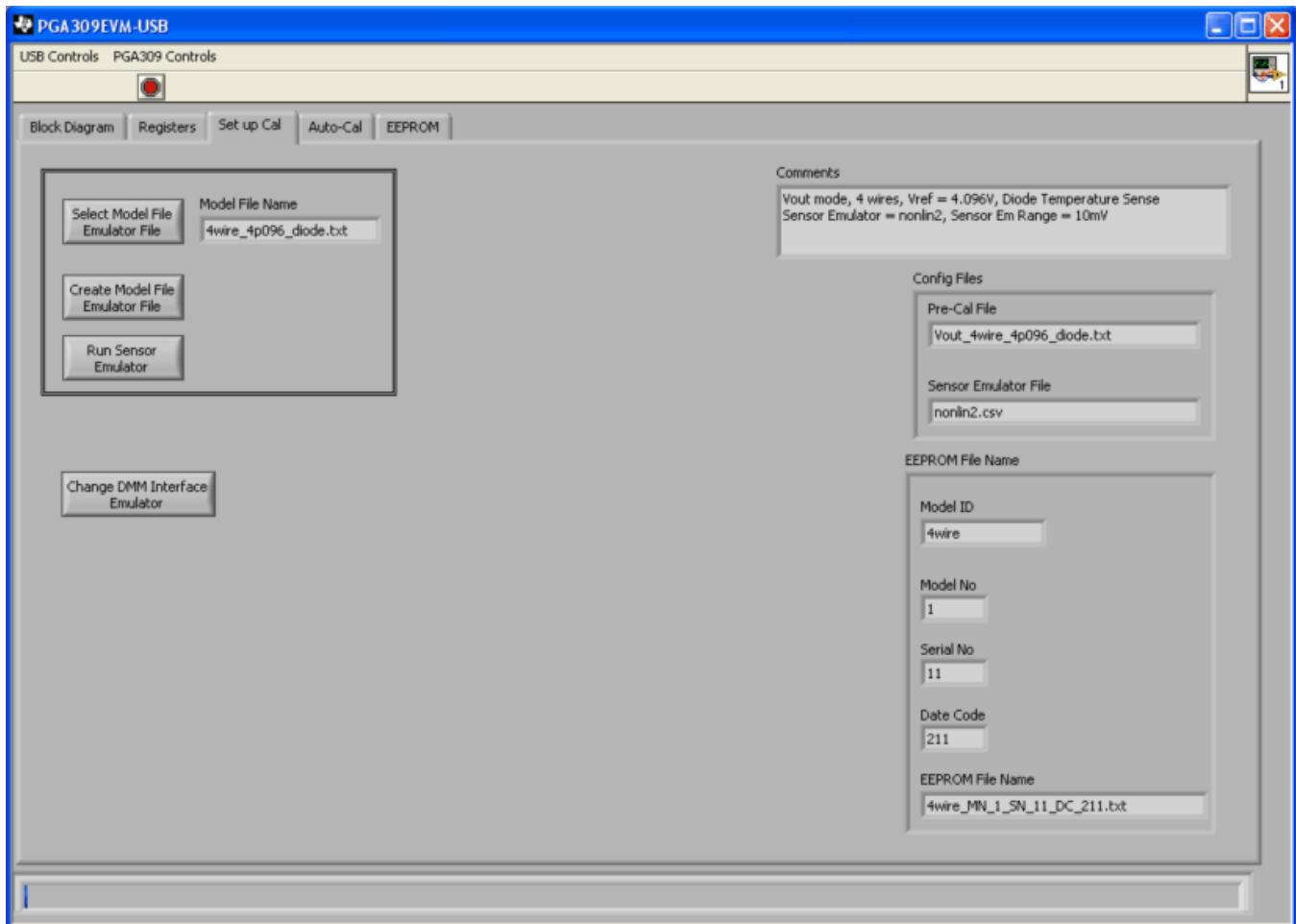

Figure 18. PGA309EVM-USB Software: Set-Up Cal Tab

The PGA309 has many different operating modes and features. The purpose of this tab is to enable users to create a *model file* that contains definitions for the operating modes and related features for a particular model. Several different model files can be created to accommodate different user requirements. For example, one model file can be created for a current-loop PGA309 module, and a different model file can be created for a four-wire, voltage-out module. Once a model file is created, the software user does not have to re-enter all the detailed settings when the model is selected and loaded for use. Details on creating and using model files are discussed later in this document; see [Section 4.12](#).

4.8 Auto-Cal Tab

As Figure 19 shows, the *Auto-Cal* (or Auto-Calibrate) tab is used to calibrate a PGA309 module over temperature. This process can be done with a real world sensor or with an emulated sensor. It is recommended that you become familiar with the calibration process using the sensor emulator. After you are confident that you understand the calibration process, you can connect your real-world sensor.

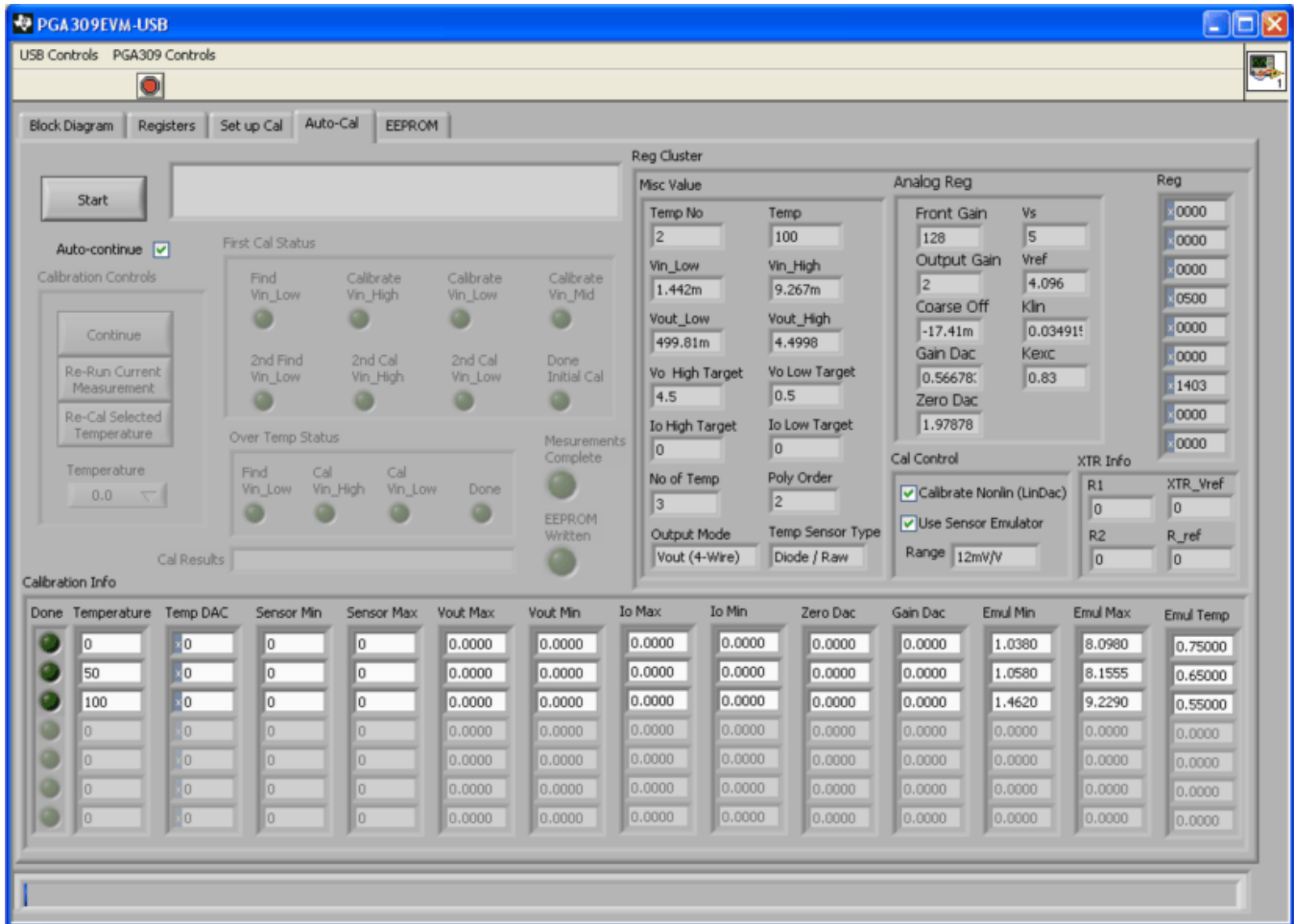

Figure 19. PGA309EVM-USB Software: Auto Calibrate Tab

4.9 EEPROM Table Tab

The EEPROM Table tab is shown in Figure 20.

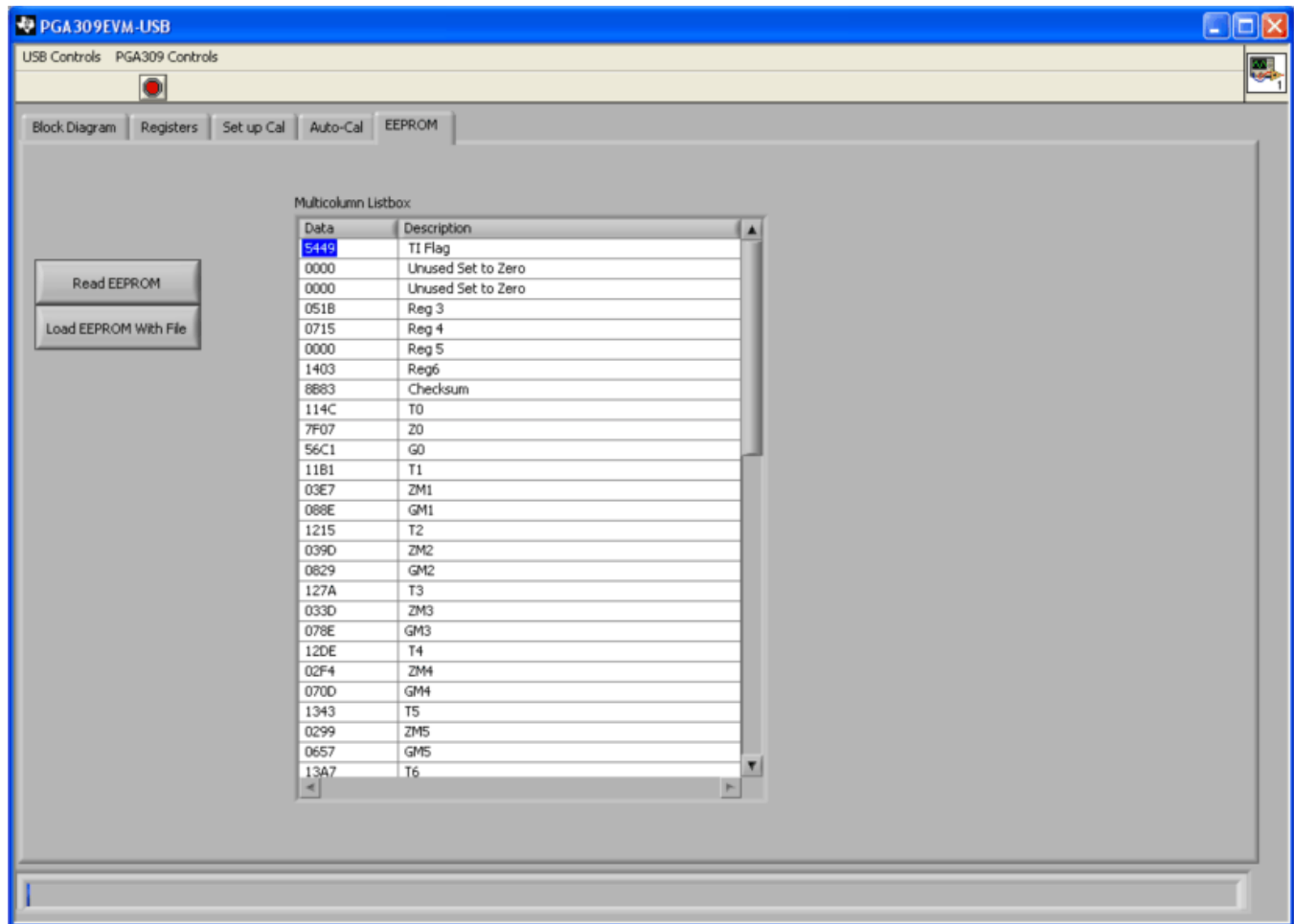

Figure 20. PGA309EVM-USB Software: EEPROM Tab

This tab contains displays for the two different sections of the PGA309 EEPROM. In general, users create the EEPROM table in the *Auto-Calibrate* tab. This tab is a debug utility that allows users to view, load, edit, and save EEPROM values

4.10 Set-Up Cal Tab: Detailed Explanation

This section presents a detailed explanation of the Set-Up Cal tab (see Figure 18). One key element of this tab is the **Select Model File** button. Pressing this button allows you to select one of the model files. The model file defines critical calibration parameters such as output configuration, reference setting, output range, and calibration temperature range. The PGA309EVM software has several model files included that are representative of typical applications. You can use these files, edit them, or create new files. Once the appropriate model file is selected, the software is ready to start calibration (that is, you can move to the Auto after the Sensor Model File is selected).

Figure 21 shows a screenshot of the Set-Up Cal tab with the *Select Model File* button highlighted. Once this button is pressed, a dialog box appears that enables users to select a specific model file.

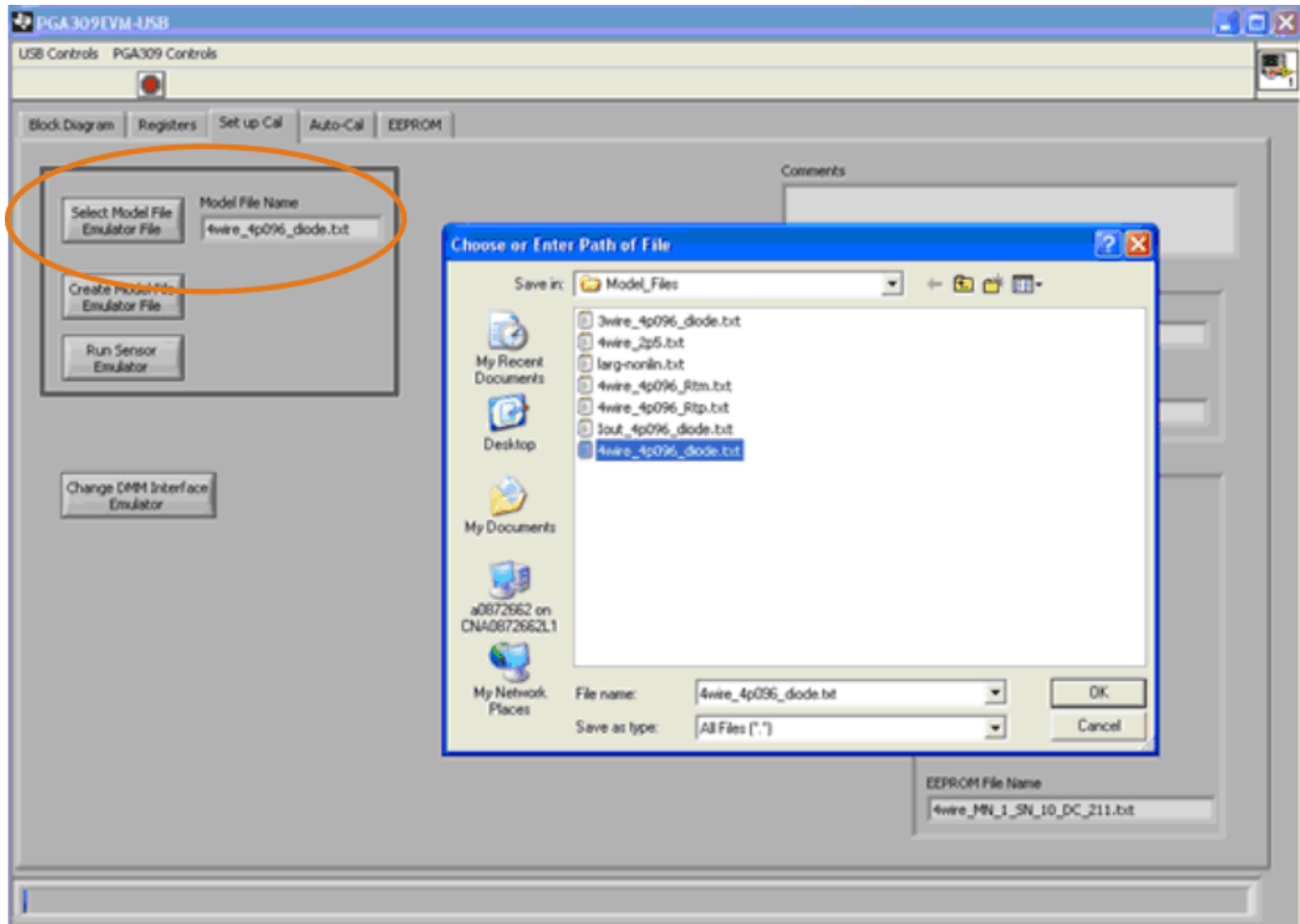

Figure 21. PGA309EVM-USB Software: Set-Up Cal Tab with Select Model File Dialog

When you want to edit a model file or create a new model file, you must first press the **Create Model File** button. [Figure 22](#) shows the *Create Model* window that opens when the Create Model File button is pressed. The Create Model window allows users to choose the Pre-Cal File, Sensor Emulator File, Model ID, Serial Number, and Model Number that will be used during the calibration process. Each of these items is discussed in detail in the following sections.

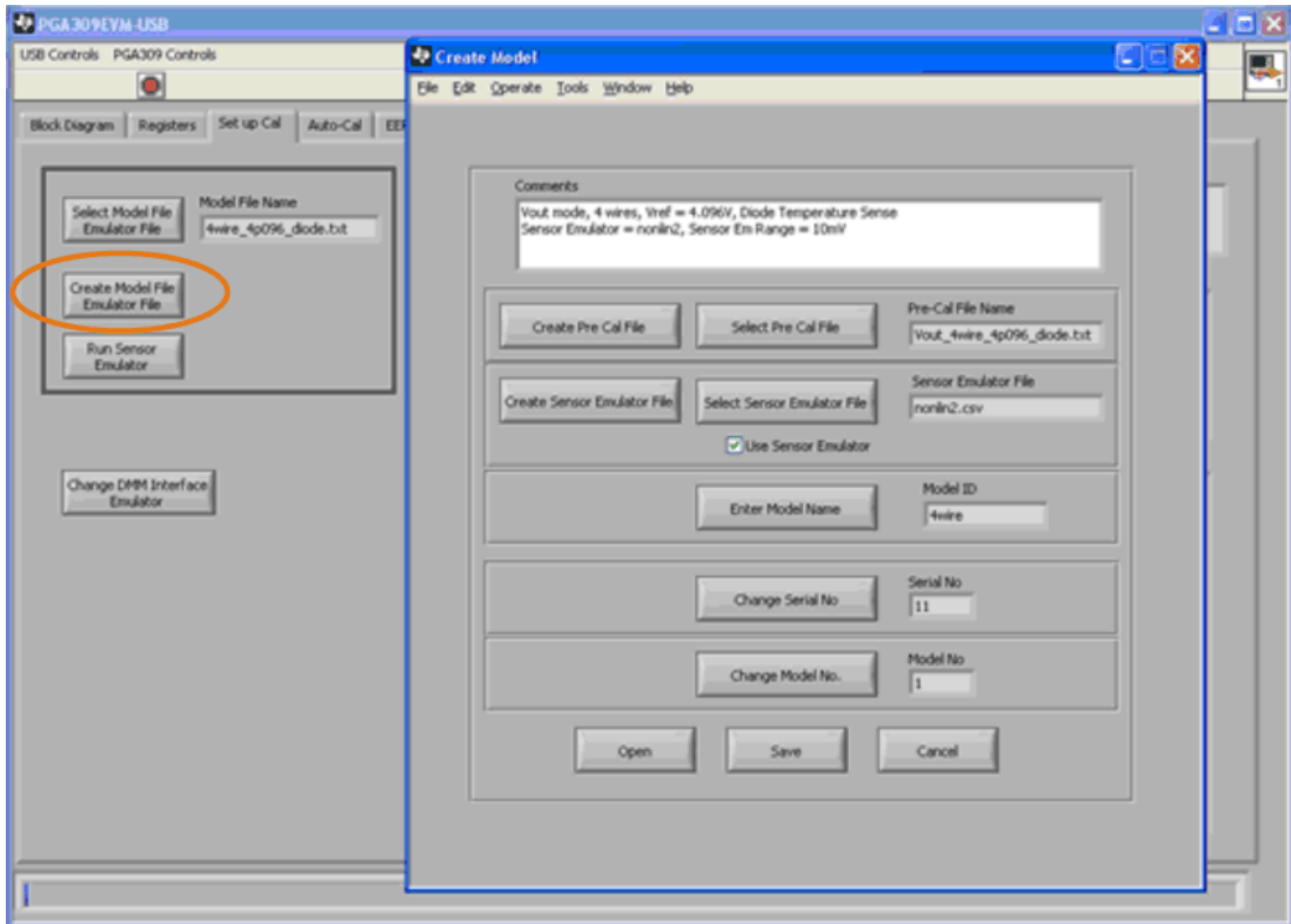

Figure 22. PGA309EVM-USB Software: Set-Up Cal Tab with Create Model Dialog

The *Sensor Emulator Control Tool* window, as [Figure 23](#) illustrates, is a pop-up window that allows you to change the sensor emulator settings. It displays three graphs that show the operation of the emulated sensor for different pressures and temperatures. The two sliders below the graphs adjust the operating temperature and load of the emulated sensor. Making changes on this tool adjusts the sensor emulator output voltage so that it acts as if it were a real-world sensor. Using the sensor emulator is very helpful when learning how to do calibrations with the PGA309 because you do not have to wait for time-consuming temperature changes. The sensor emulator can also help to verify the accuracy of your electronics without sensor hysteresis and non-repeatability issues.

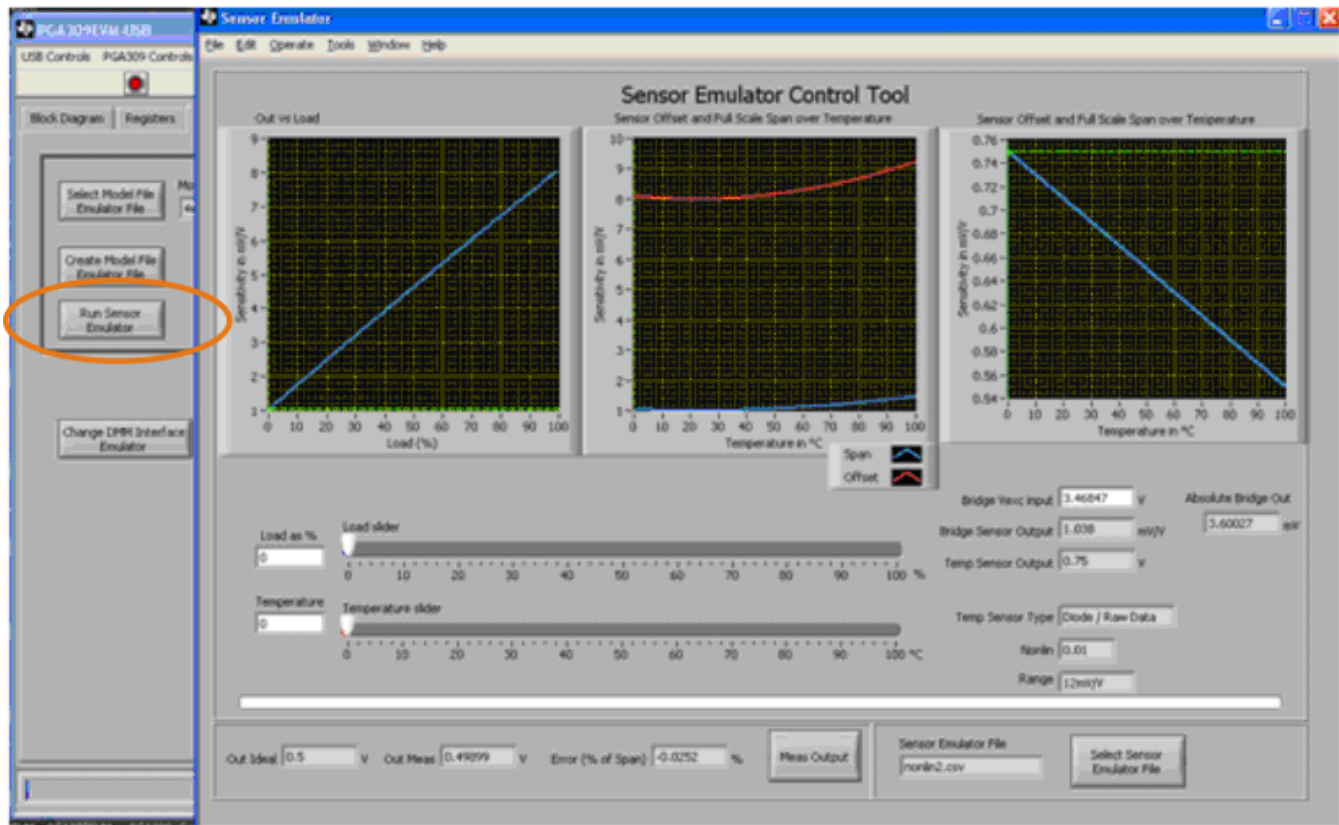

Figure 23. PGA309EVM-USB Software: Set-Up Cal Tab with Sensor Emulator Control Tool Dialog

The **Change DMM Interface** button is used to select the measurement resource for reading the voltage or current output of the PGA309. The PGA309EVM has an onboard ADC that can be used to perform all measurements. This ADC is convenient for initial evaluation because no additional equipment is required. For subsequent experiments, you may want to use a precision DMM to make measurements. The Agilent 34401A (not included with EVM kit) can be used to measure the voltage or current output of the PGA309. Communication with the Agilent 34401A can be managed using the computer serial port (RS-232) or the National Instruments' GPIB-USB-HS communications hardware.

The Configure DMM Interface utility pop-up dialog (as shown in [Figure 24](#)) allows you to select from one of these options:

- Built In A/D Converter on EVM
- RS-232 for 34401a
- GPIB-USB-HS for 34401a

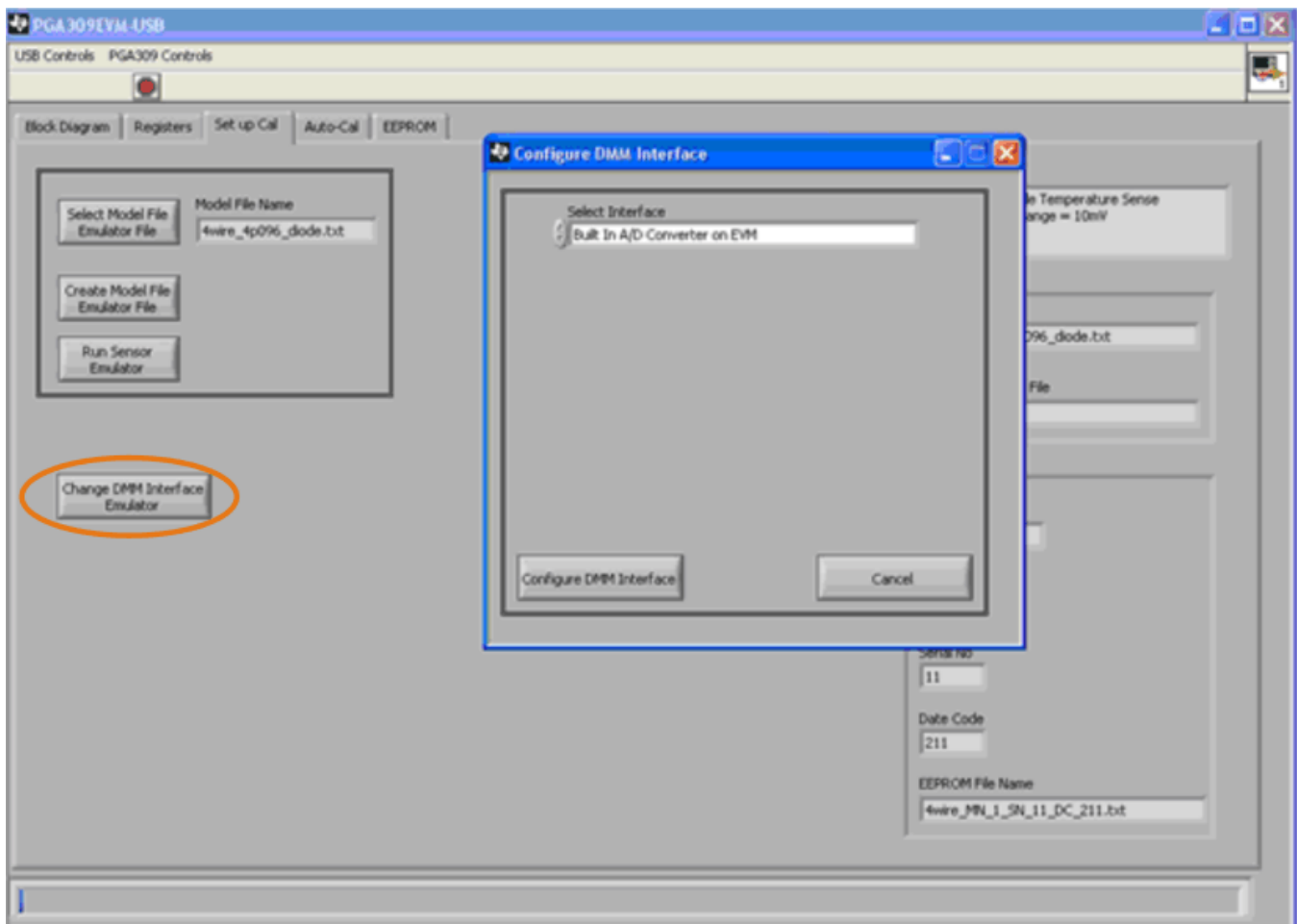

Figure 24. PGA309EVM-USB Software: Set-Up Cal Tab with Configure DMM Interface Dialog

NOTE: If you use the RS-232 interface, you must configure the Agilent 34401a settings accordingly. If you have difficulty communicating with the instrument, make sure that the instrument is set to RS-232, and that the baud rate and parity match the software settings. If you are using the GPIB-USB-HS, make sure that the interface is set to *HP-IB / 488* and that the address matches the software setting.

4.11 Auto-Cal Tab: Detailed Description

The Auto-Cal tab is used to perform a fully-automated calibration of a PGA309 sensor module. This calibration can be done using either the sensor emulator or a real-world sensor module. If you use the sensor emulator, the EVM automatically adjusts the sensor emulator output throughout the calibration. When a real-world sensor is calibrated, the program pauses periodically and allows users to adjust the sensor stimulus (such as pressure) and temperature settings.

Calibration is initiated using the **Start** button (shown in Figure 25). The *Auto-Continue* feature can be used to allow calibration to continue without pausing. If the Auto-Continue checkbox is not selected, the software pauses after each calibration step to allow for manual adjustment of temperature or stimulus settings.

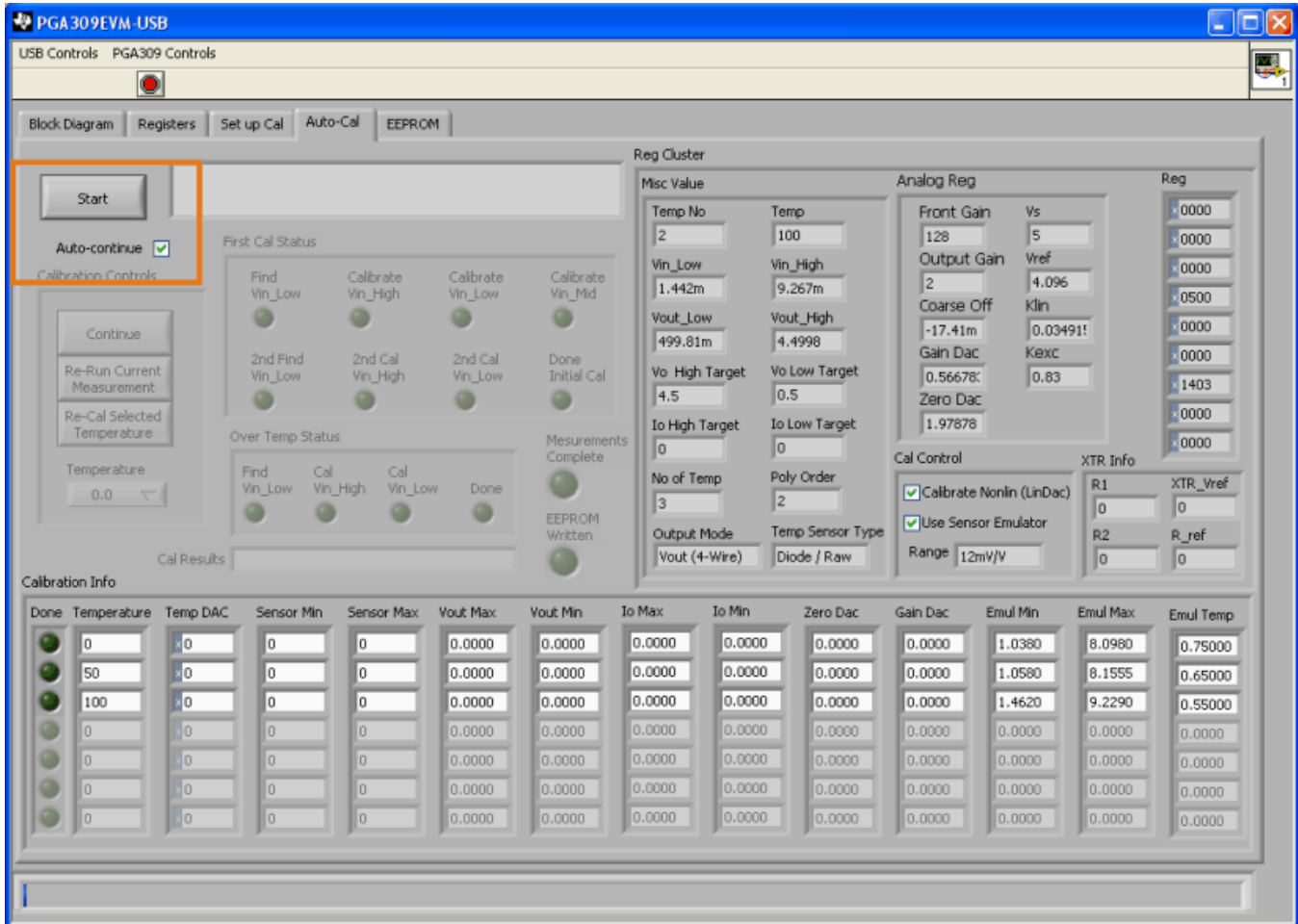

Figure 25. PGA309EVM-USB Software: Auto Calibrate Tab with Auto-Continue Feature Enabled

Figure 26 illustrates additional details of the Auto-Cal tab. Note that the **Continue** button blinks to indicate that the program is waiting for the user to adjust the stimulus or temperature settings; press the button to continue the calibration process. The *Calibration Info* section is the over-temperature data measured throughout the calibration. The *Reg Cluster* section contains the current register information that is measured.

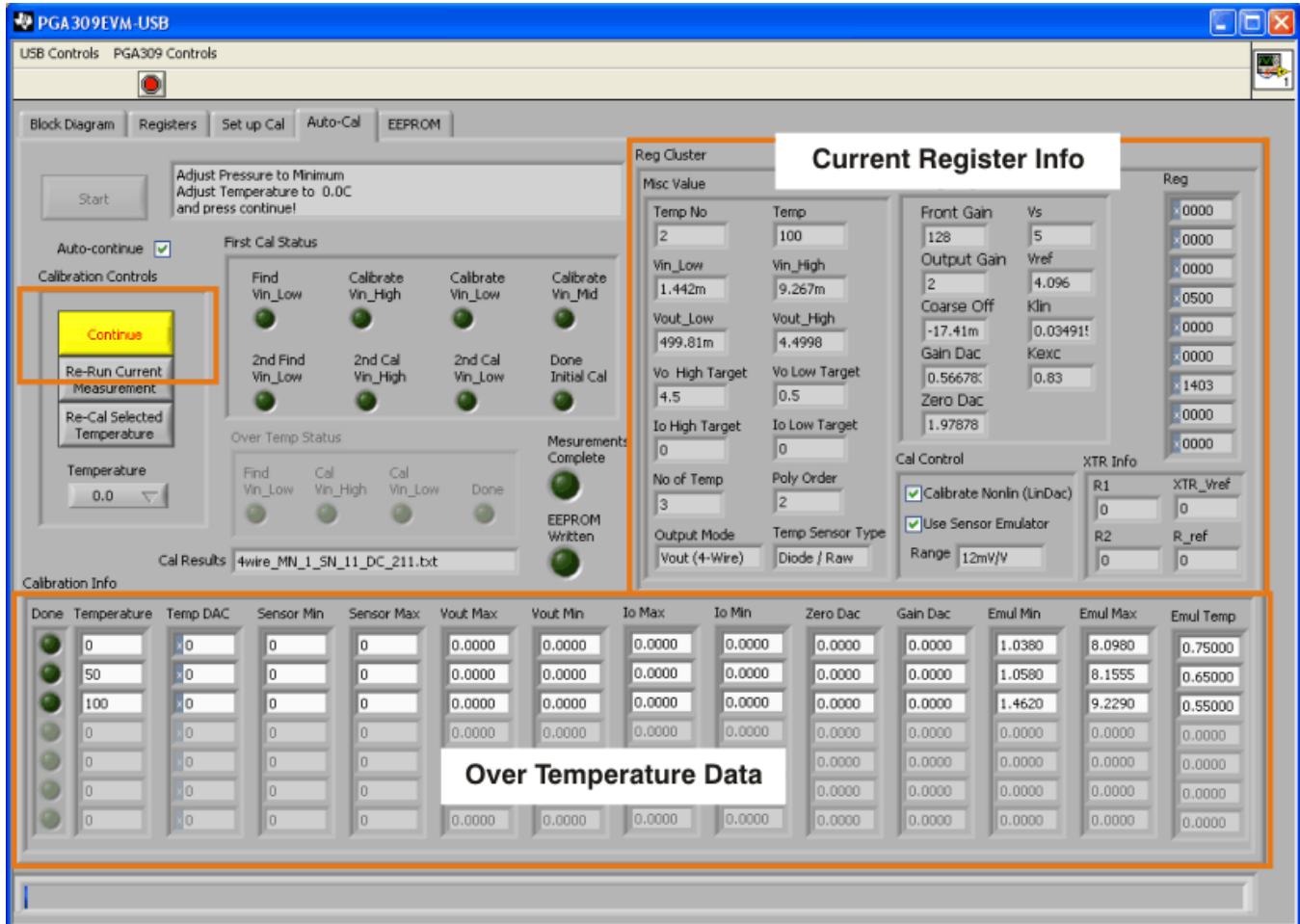

Figure 26. PGA309EVM-USB Software: Auto Calibrate Tab at Start of Calibration Process

Once a calibration is in progress, the display shows a screen similar to that in Figure 27.

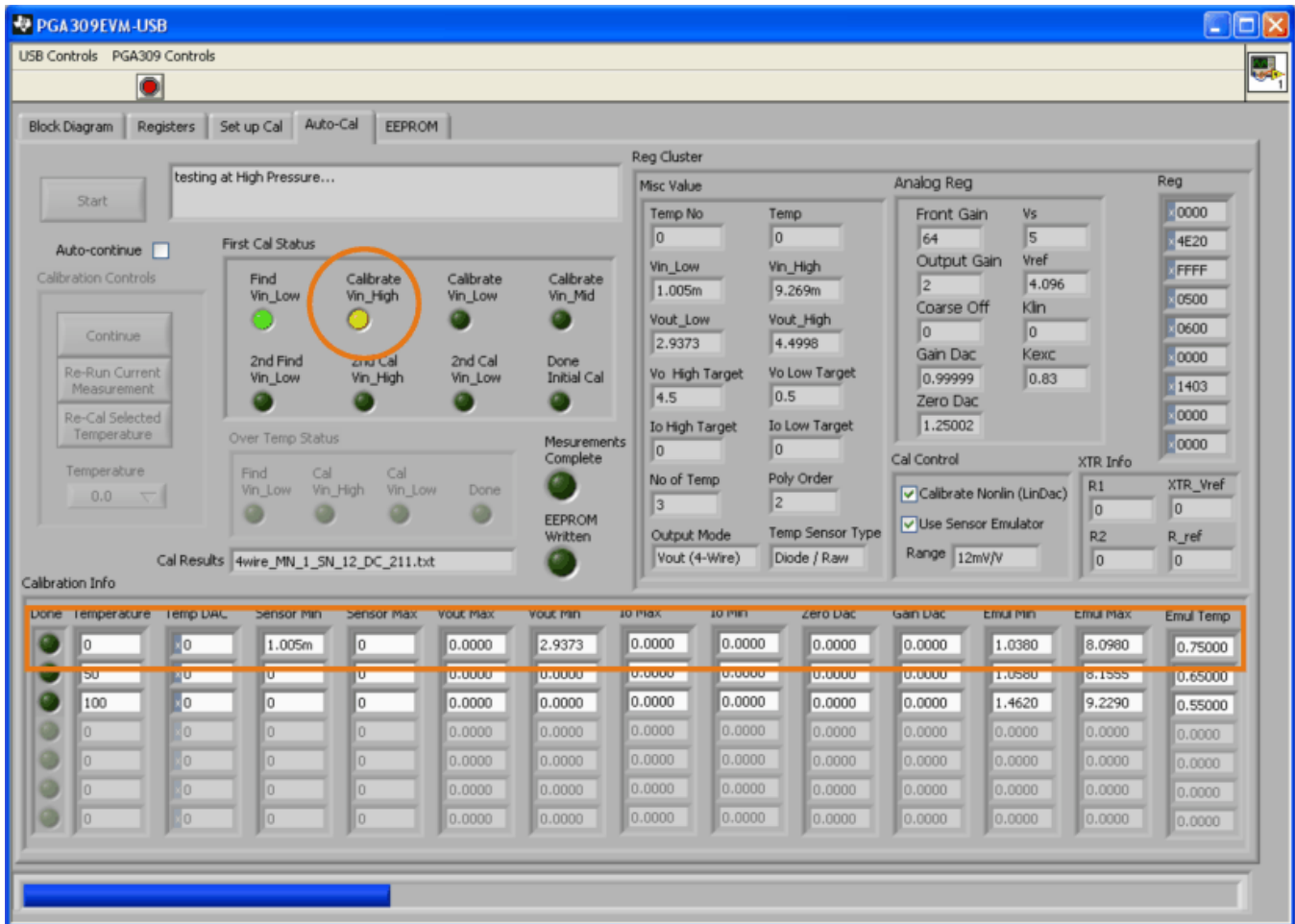

Figure 27. PGA309EVM-USB Software: Auto Calibrate Tab with Calibration in Progress

The progress of the calibration is shown using LED-style indicators. A green indicator means that the step is completed; a blinking indicator indicates that the step is currently in progress. In Figure 27, the *Find Vin_Low* step is complete and the *Calibrate Vin_High* step is in progress.

Figure 28 illustrates the Auto-Cal tab after the initial calibration completes and the second calibration has started. Note that all the LEDs in the *First Cal Status* section are green, and the entire section is shaded gray. The shading and green LED marking indicates that the first calibration process is complete. The first calibration includes additional steps (for example, selecting gains and adjusting the non-linearity correction) that are not required during later calibrations.

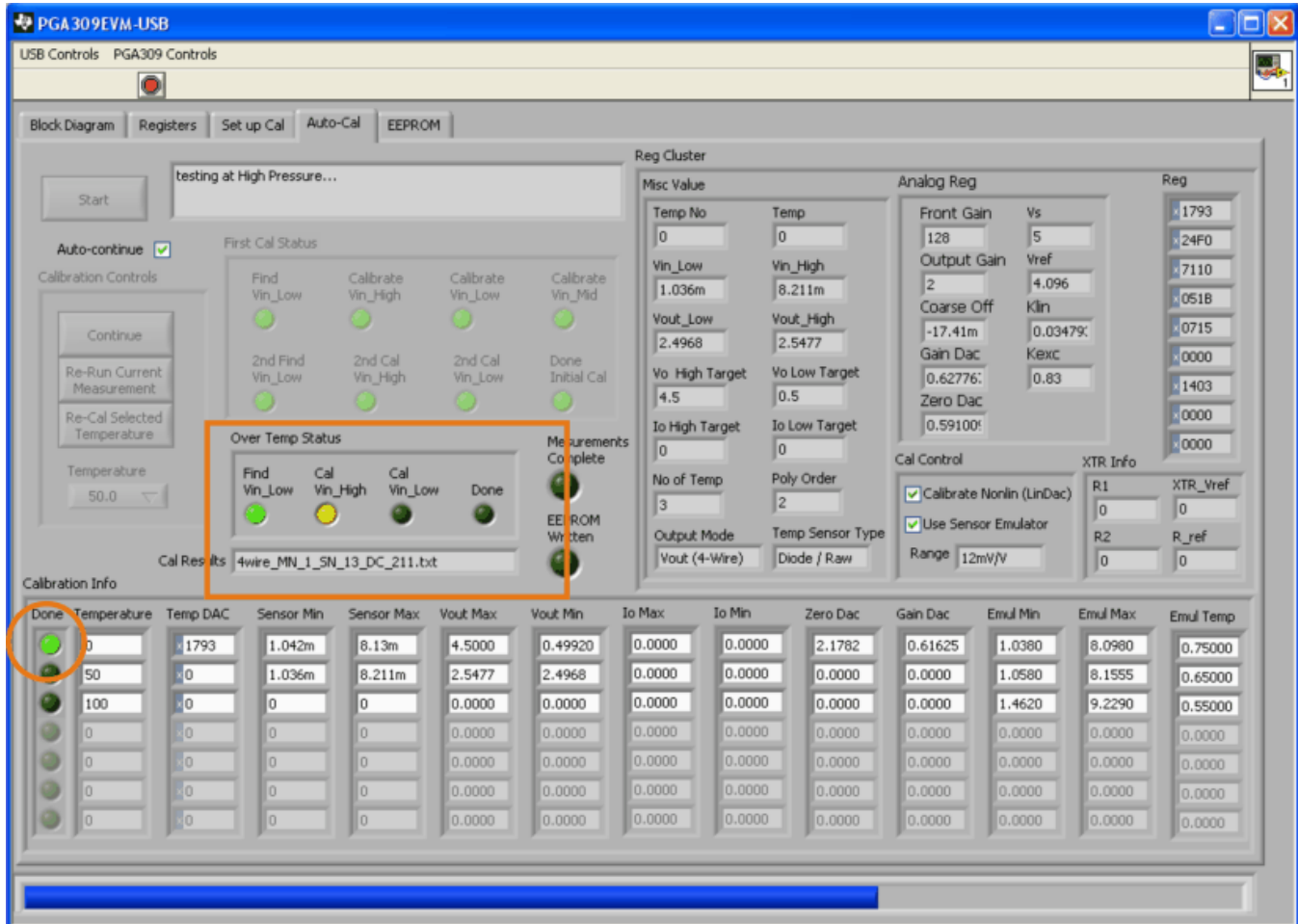

Figure 28. PGA309EVM-USB Software: Auto Calibrate Tab with Second Calibration in Progress

When the calibration is complete, the screen appears as shown in Figure 29. At this point, all of the over-temperature measurements have been completed, the EEPROM look-up table was created, and the look-up table was written to the EEPROM.

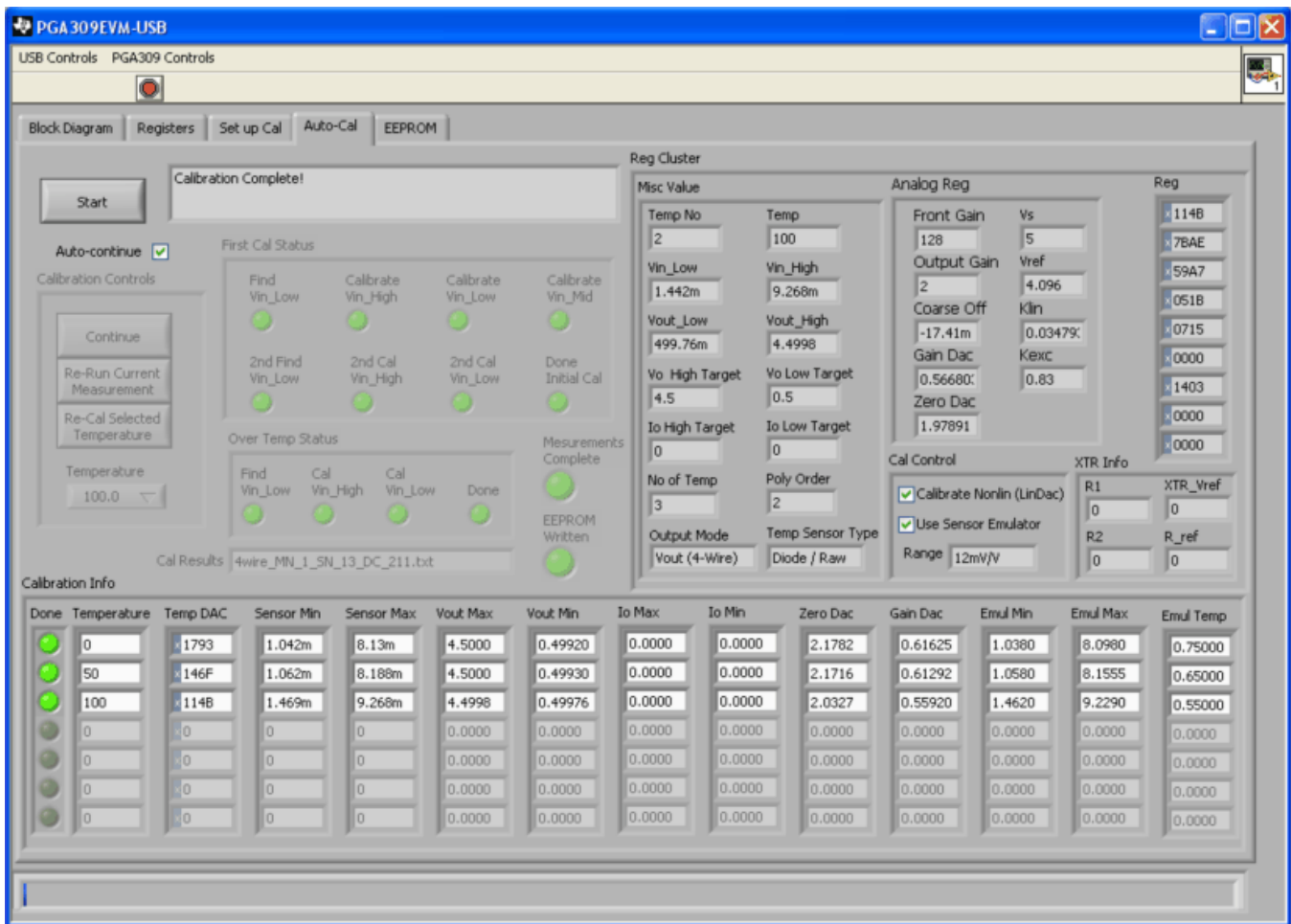

Figure 29. PGA309EVM-USB Software: Auto Calibrate Tab with Both Calibrations Complete

4.12 Create Model File: Detailed Discussion

One key file used during calibration is the *pre-cal* file. The pre-cal file defines the initial register settings, supply voltage, output range, output mode, and other key parameters required for the calibration.

When creating a new model file, users may either create a new pre-cal file or use an existing one if a file already exists that meets your requirements. Select a saved pre-cal file using the **Select Pre-Cal File** button. The *Load Pre-Cal* file dialog is displayed, as [Figure 30](#) shows.

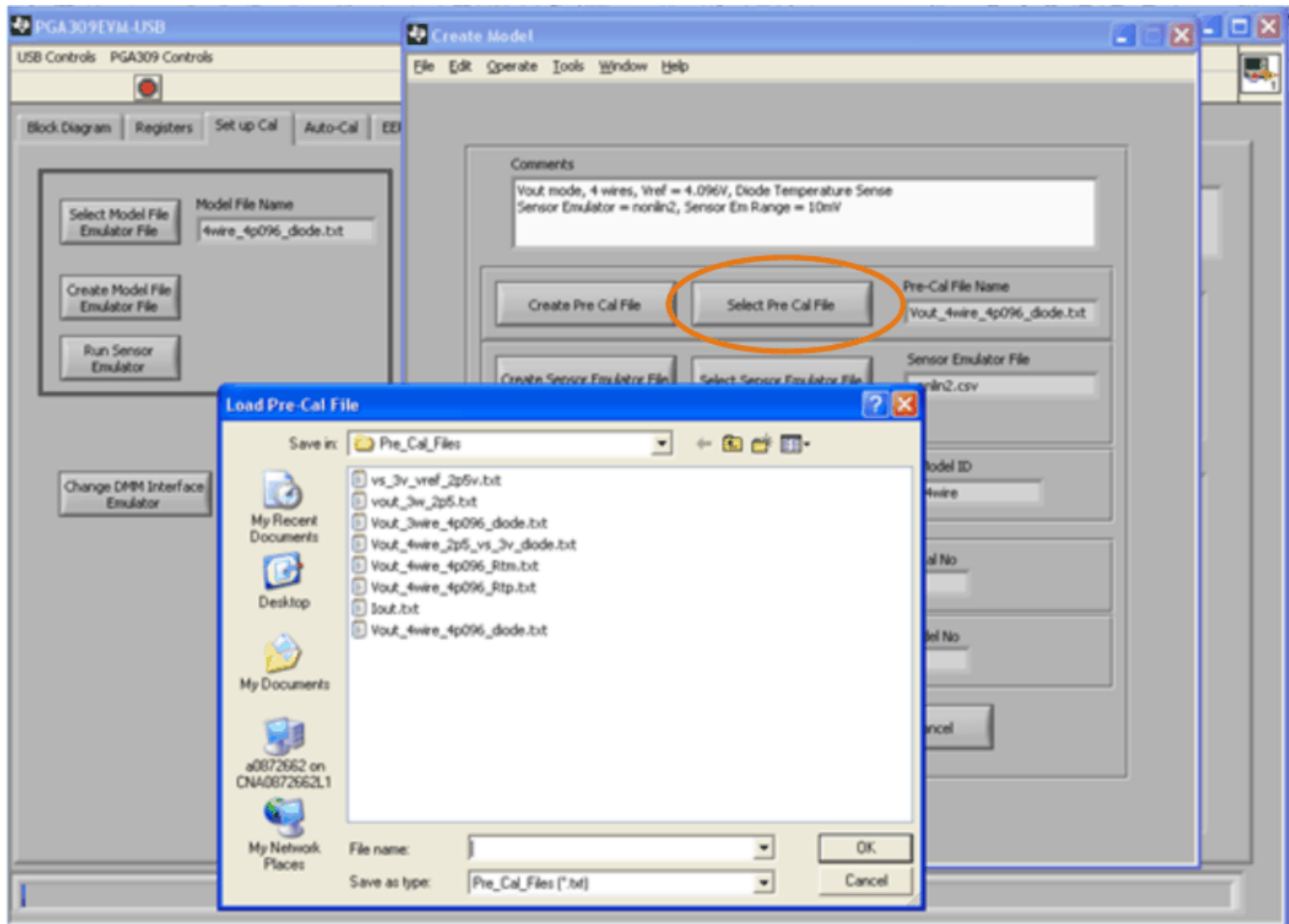

Figure 30. PGA309EVM-USB Software: Create Model, Select Pre-Cal File

When creating a model file, it may be necessary to modify or create a new pre-cal file. Press the **Create Pre-Cal File** button to start this process. Figure 31 shows the utility that appears when you need to create a new pre-cal file. Details for editing a pre-cal file are covered in Section 4.13. The pre-cal file contains the initial register settings, power-supply settings, output modes, output ranges, and other pertinent settings.

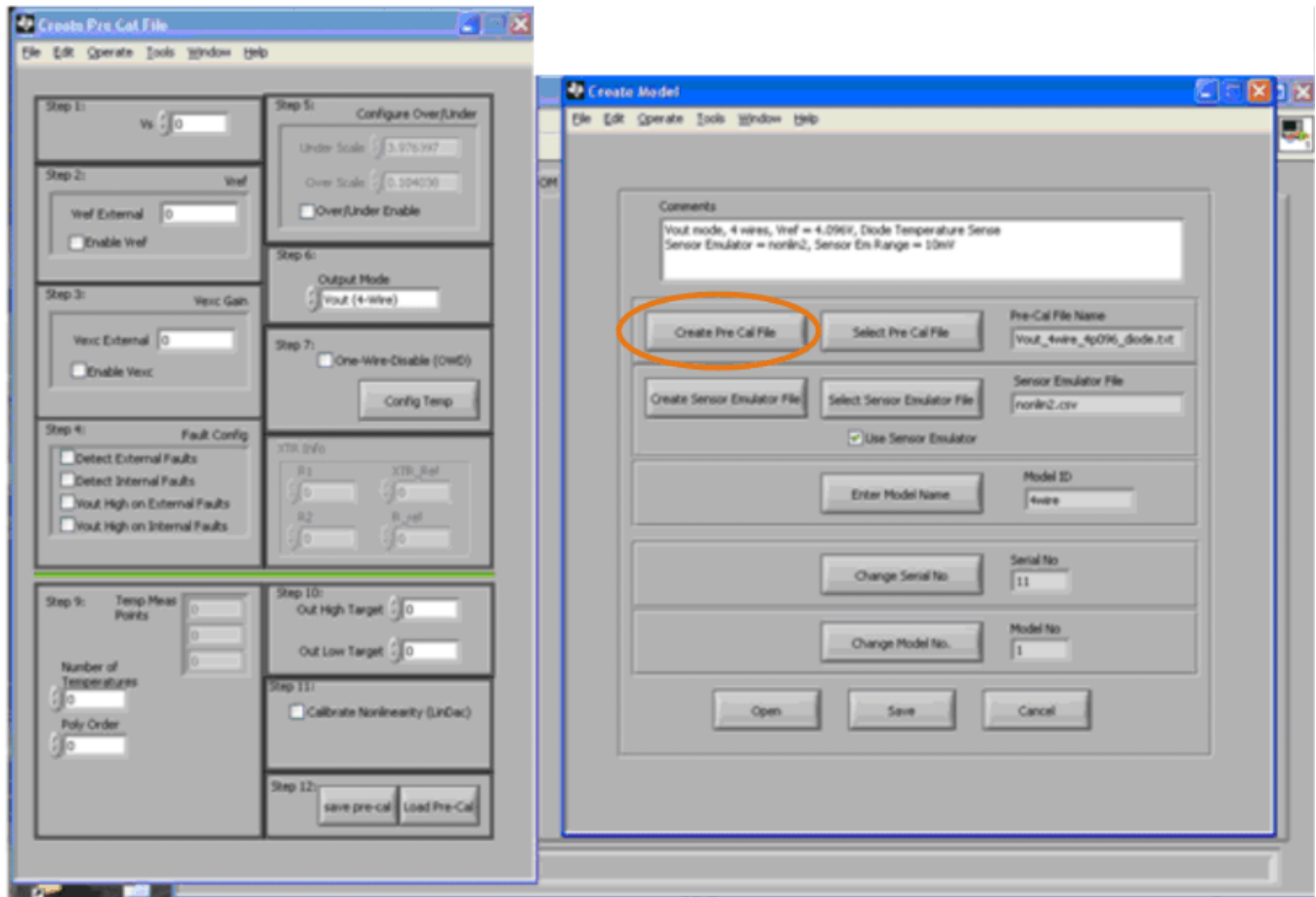

Figure 31. PGA309EVM-USB Software: Create Model Dialog with Create Pre-Cal File Active

The Sensor Emulator Control Tool is a pop-up window that can be accessed from the Sensor Definition tab, as Figure 32 shows. It displays three graphs that show the operation of the emulated sensor for different pressures and temperatures. The two sliders below the graphs adjust the operating limits.

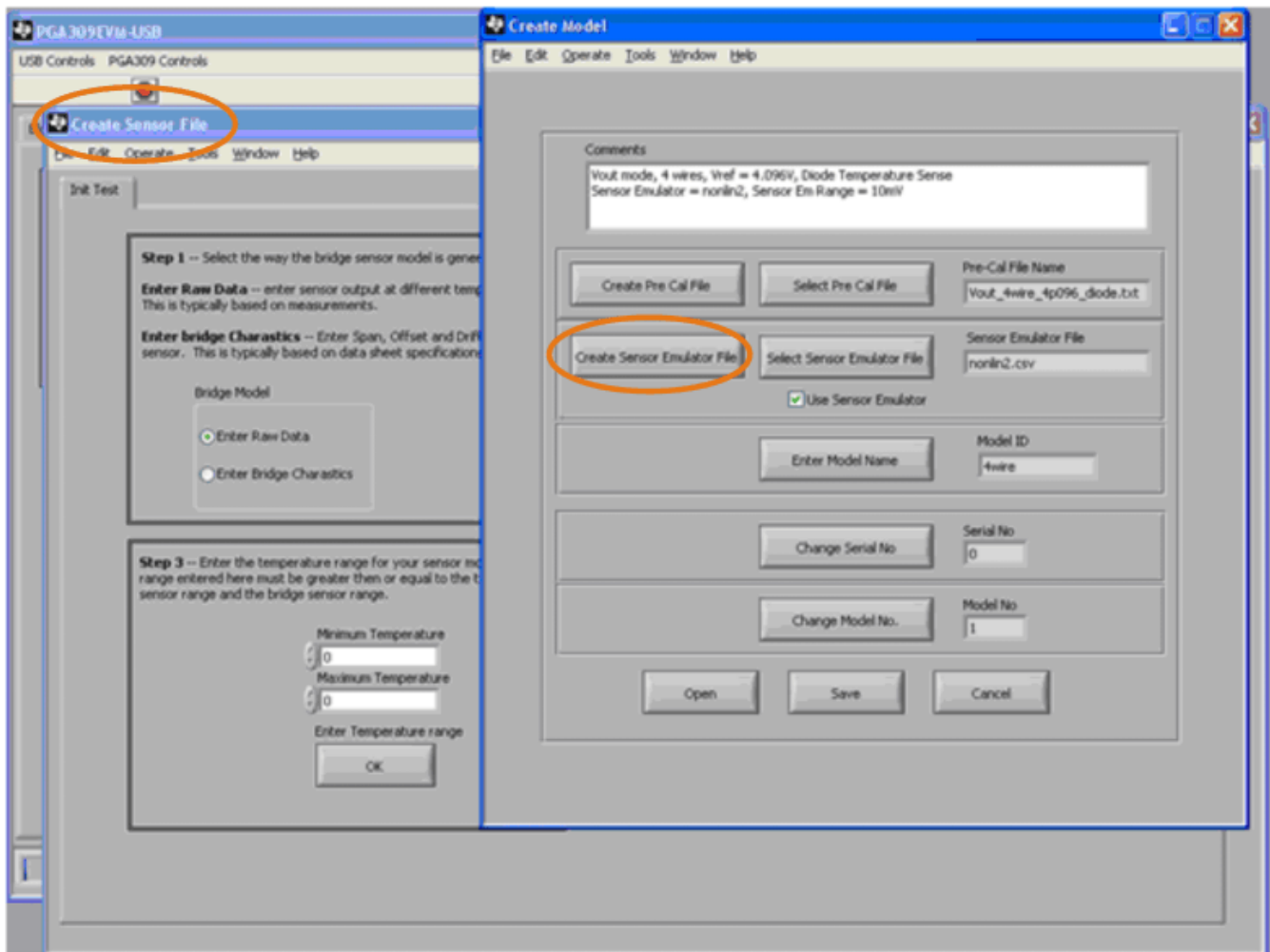

Figure 32. PGA309EVM-USB Software: Create Model Dialog with Create Sensor File Active

The model ID, serial number, and model number can be changed by pressing the three buttons highlighted in Figure 33. These numbers are used in the file name when data are stored at the end of each calibration.

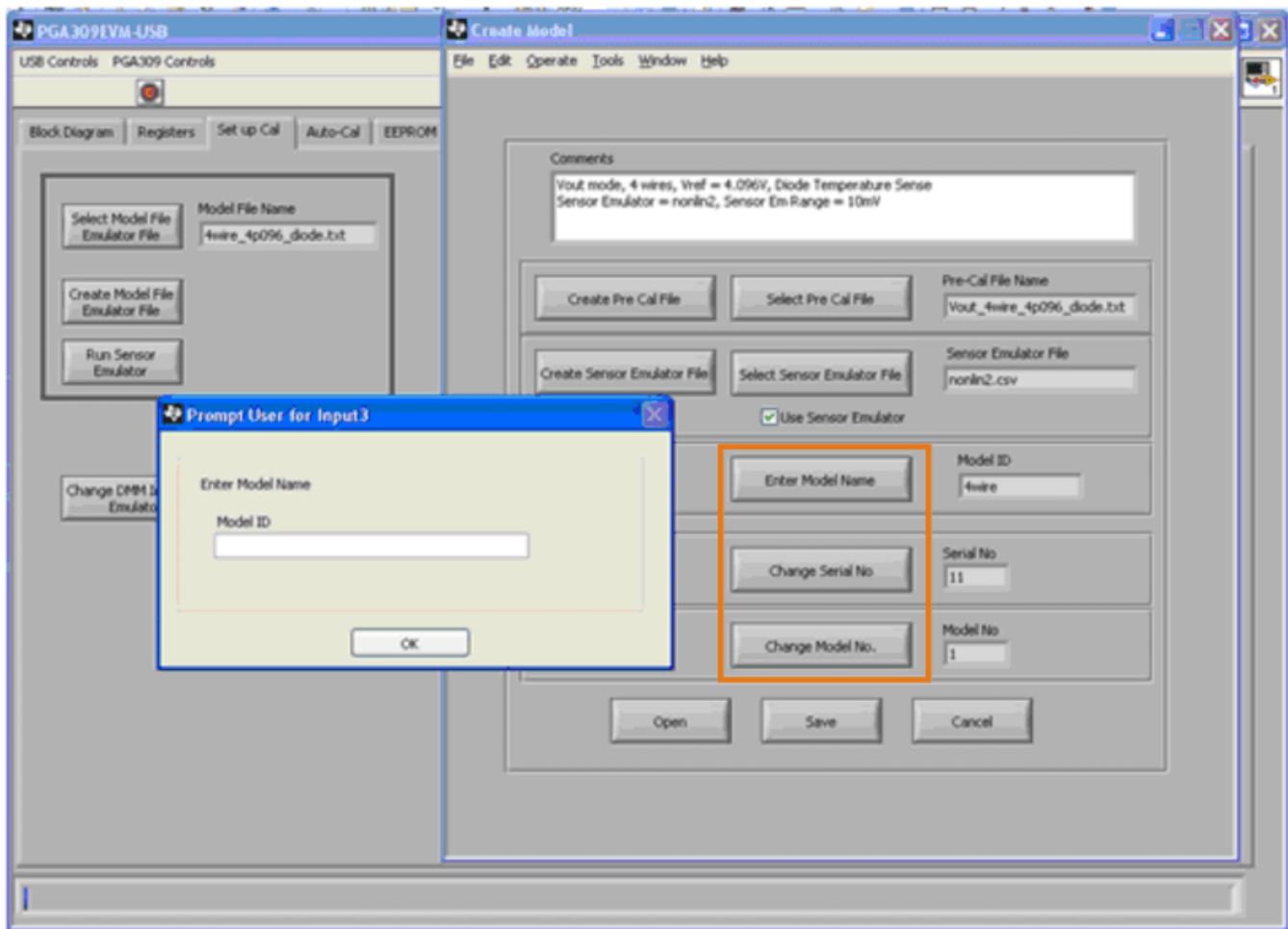

Figure 33. PGA309EVM-USB Software: Create Model Dialog with Model ID Active

The file name structure is unique, and follows this pattern:

- File Name = 4wire_MN_1_SN_11_DC_0311.txt
- Model Name = 4wire
- Serial No = 11 (incremented automatically at the end of each calibration)
- Model number = 1
- Date code = 0311 (generated automatically by computer clock, week = 03, year = 11)

When the model file is completely edited, save the file by hitting the **Save** button, as indicated in Figure 34. If you wish to overwrite an older file, select an existing file name and then click **OK**.

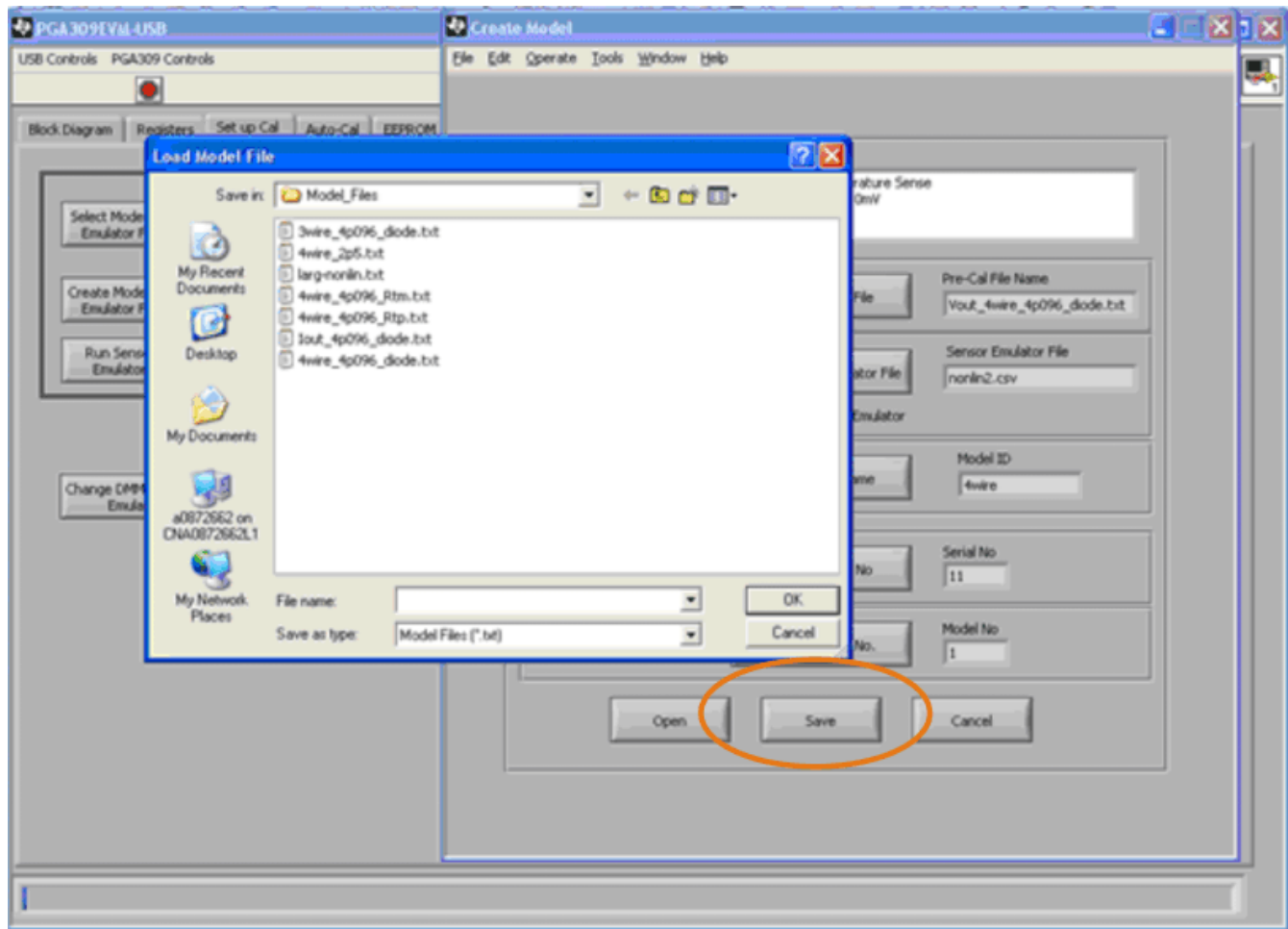

Figure 34. PGA309EVM-USB Software: Create Model Dialog with Save File Active

4.13 Create Pre-Cal File: Detailed Description

The Create Pre-Cal File is a utility that allows users to create a separate file with all of the initial register settings, power-supply voltages, output configurations, and other relevant requirements. The Create Pre-Cal File window, illustrated in Figure 35, has 12 fields labeled Step 1 to Step 12. It is recommended that you edit the 12 fields in sequential order because some of the fields depend on inputs to previous fields. Each of the 12 fields are described in Table 8.

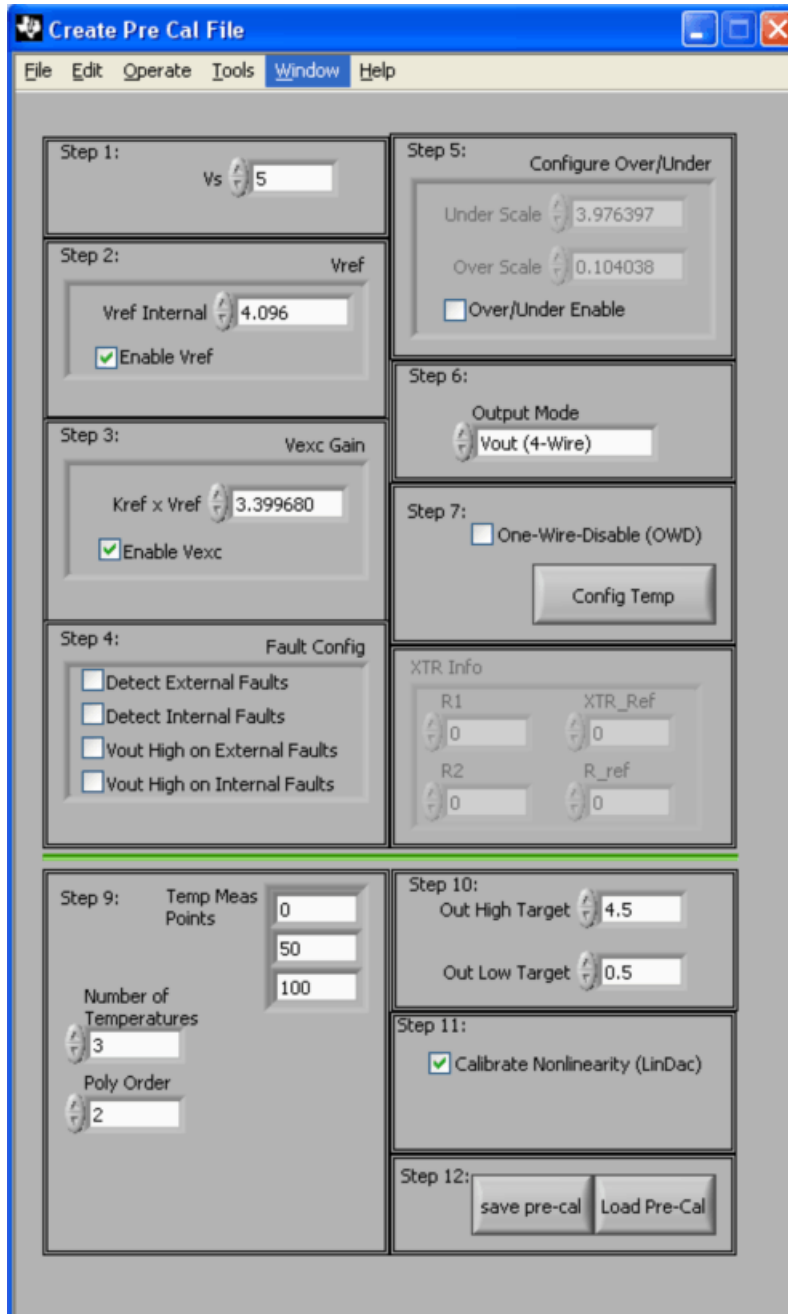

Figure 35. PGA309EVM-USB Software: Create Pre-Cal File Dialog with Sensor Emulator Control Tool

Table 8. Create Pre-Cal File Field Descriptions

Step No	Description
1: Vs	Sets the PGA309 power-supply voltage to be used.
2: Vref	Selects different internal references or allows for external reference
3: Vexc	Selects the V_{EXC} value or disables V_{EXC}
4: Fault Config	Enables fault configuration. If fault detection is used, it is disabled during calibration and enabled at the end of calibration.
5: Configure Over / Under	Allows users to set an over-scale or under-scale limit or disable the limit. This feature is disabled during calibration and enabled at the end of the calibration.
6: Output Mode	Allows users to select between the three different PGA309 output modes (3-wire V_{OUT} , 4-wire V_{OUT} , and I_{OUT}).
7: One-Wire Disable and Configure Temperature	<i>One-wire disable</i> is typically used in conjunction with 3-wire V_{OUT} mode. This feature is described in detail in the PGA309 device user's guidexx. Press <i>Configure Temperature</i> to set up the temperature sensor for the PGA309. This feature is described in detail in section xx of this document.
8: XTR Info	This section is only active when current loop mode is used.
9: Temperature List for Cal	This section allows users to select the number of temperatures in the calibration and the temperature values. A typical calibration includes three temperatures. Additional temperatures can be added for more accuracy.
10: Output Targets	This section lets users set the post-calibration targets for the output voltage or current. For voltage output, typical targets are 0.5 to 4.5. For current output, typical targets are 0.004 to 0.02.
11: Calibrate Nonlinearity	This section allows users to calibrate nonlinearity versus stimulus. If your sensor does not have nonlinearity versus stimulus issues, you can skip this calibration step.
12: Save or Load Files	When you have finished editing the pre-cal file, you can either save the file or load the file to the EVM.

4.14 Create Sensor Emulator File: Detailed Discussion

The *Create Sensor File* utility enables users to create a sensor data file for the sensor emulator tool in order to generate signals that emulate the behavior of a real-world sensor. This utility requires a multi-step process to create a sensor emulator file. [Figure 36](#) shows the first three steps in the process.

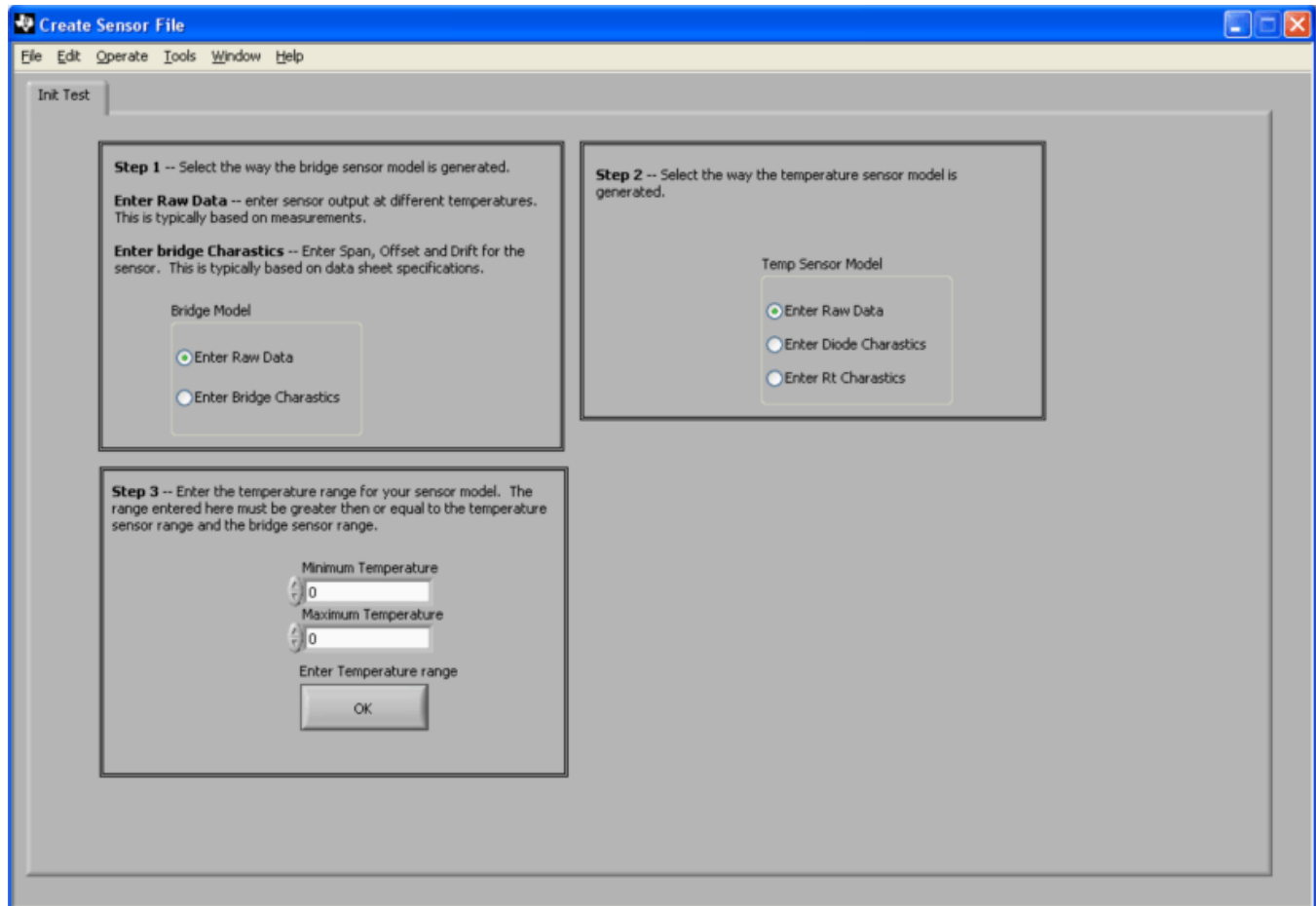

Figure 36. PGA309EVM-USB Software: Create Sensor Emulator File

Step 1. Select the way that data are entered for the model.

The most common way is to enter raw data. Raw data can either be measured sensor data or values input from a product data sheet. Raw data are given as sensor outputs at specific temperatures. A second way to enter the sensor data is to select the *Enter Bridge Characteristics* option. When using this option, you must also enter the drift and offset numbers in ppm/°C directly from the data sheet.

Step 2. Specify the type of temperature sensor used (diode, RT, or raw).

Note that you cannot use the emulator for the internal temperature sensor mode of operation. For both the diode and Rt methods, the emulator generates an input signal that matches the real-world equivalent. The raw data option for the temperature sensor allows you to enter any arbitrary voltage vs temperature data. This option could be used for unique temperature sensor signals (for example, not the diode or Rt methods).

Step 3. Enter the temperature range for the sensor emulator function to operate in.

After the temperature range is entered, additional tabs appear that must be completed; these tabs are noted in [Figure 37](#).

Figure 37 the additional tabs that appear after the *Enter Temperature Range* button is pressed. Note that the tabs correspond to the options selected in Step 1 and Step 2. You must provide the information requested on each tab and then save the sensor emulator file before proceeding to use it.

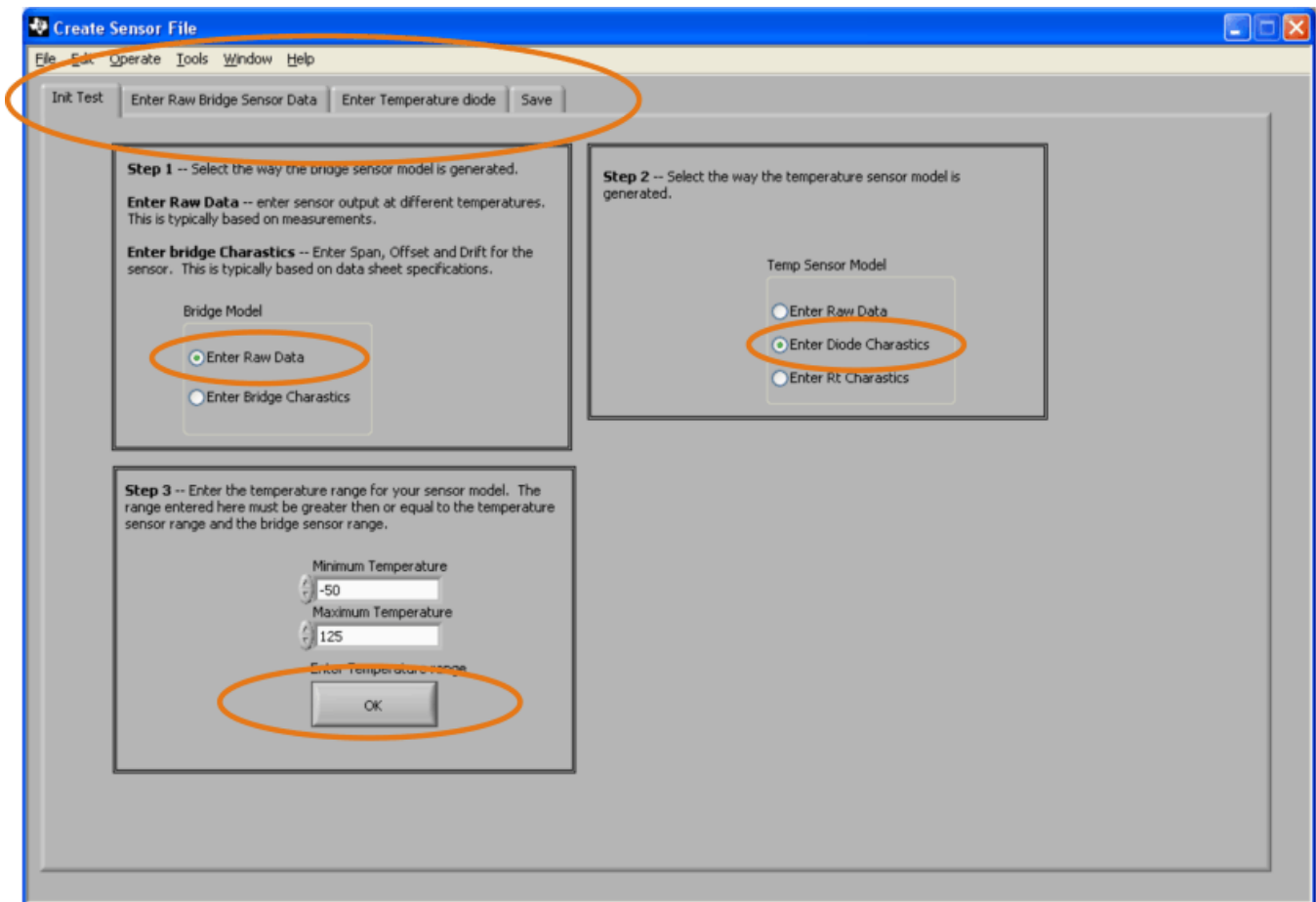

Figure 37. PGA309EVM-USB Software: Create Sensor Emulator File with Additional Tabs

Figure 38 illustrates the tab for entering raw bridge sensor data. This tab appears after the temperature range is set on the first tab

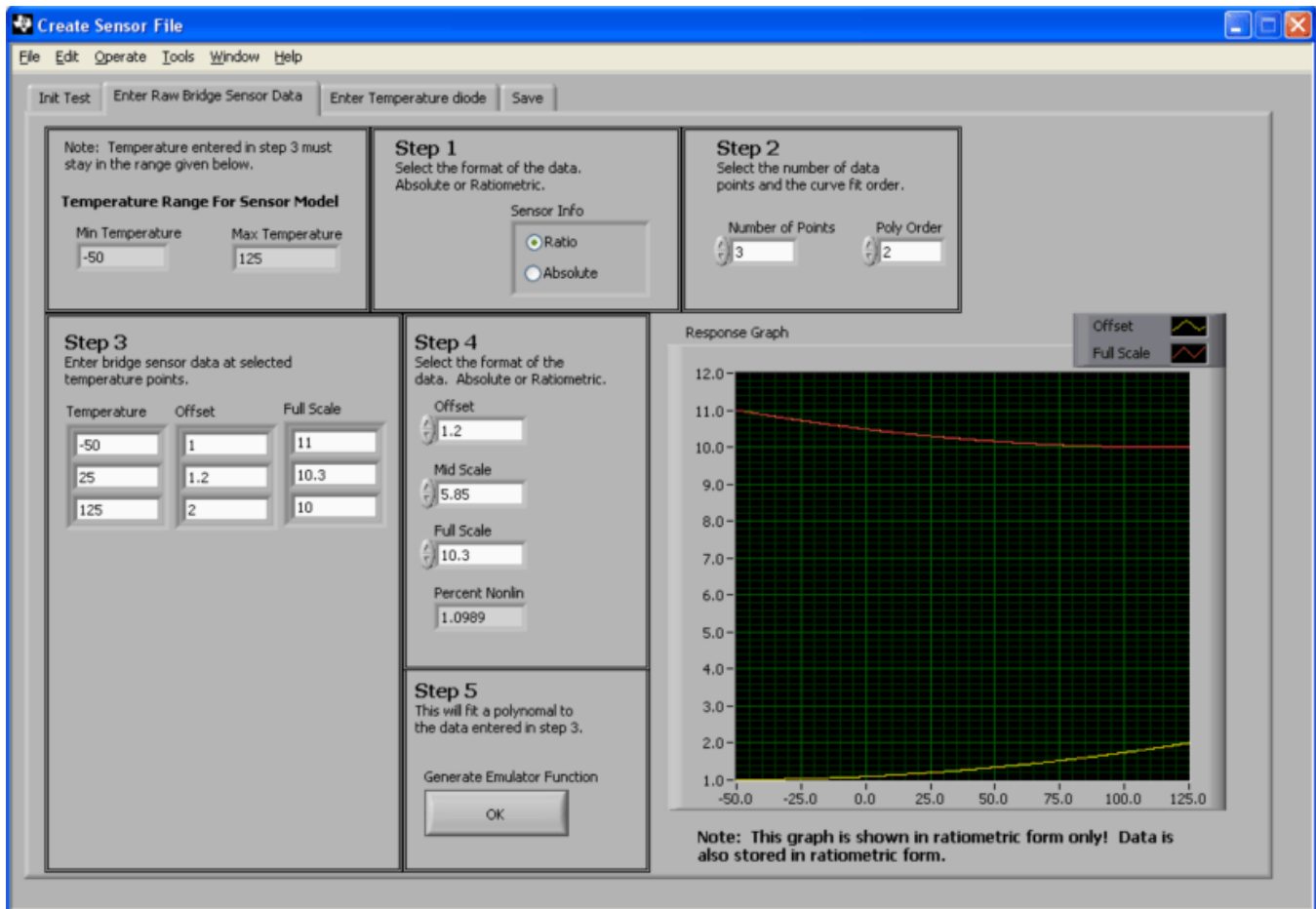

Figure 38. PGA309EVM-USB Software: Create Sensor Emulator File by Entering Raw Bridge Sensor Data

In this example, bridge sensor drift information is loaded by entering the sensor raw data. There are five steps to this process.

Step 1. Choose the data format (absolute or ratiometric sensor output).

Ratiometric output is the most common way to enter sensor data. Ratiometric sensor data are entered in mV/V. For absolute data, you must enter the sensor data in mV and the sensor excitation voltage in V.

Step 2. Enter the number of temperature points and the curve fit polynomial order.

As you adjust the data in Step 2, the size of the table in Step 3 adjusts accordingly.

Step 3. Enter the bridge sensor data at selected temperature points.

This step is performed automatically as you adjust the data in Step 2. You can also make changes to the data points in this step.

Step 4. Enter the nonlinearity data.

These data can be measured at any temperature. The mid-scale point computes the Percent Nonlinearity value displayed.

Step 5. Press the button to generate the emulator function.

Once the button is pressed, a chart that describes the over-temperature drift is displayed.

The next step in the process of generating a sensor emulator file is to enter the temperature sensor data. The example shown in [Figure 39](#) uses diode temperature data.

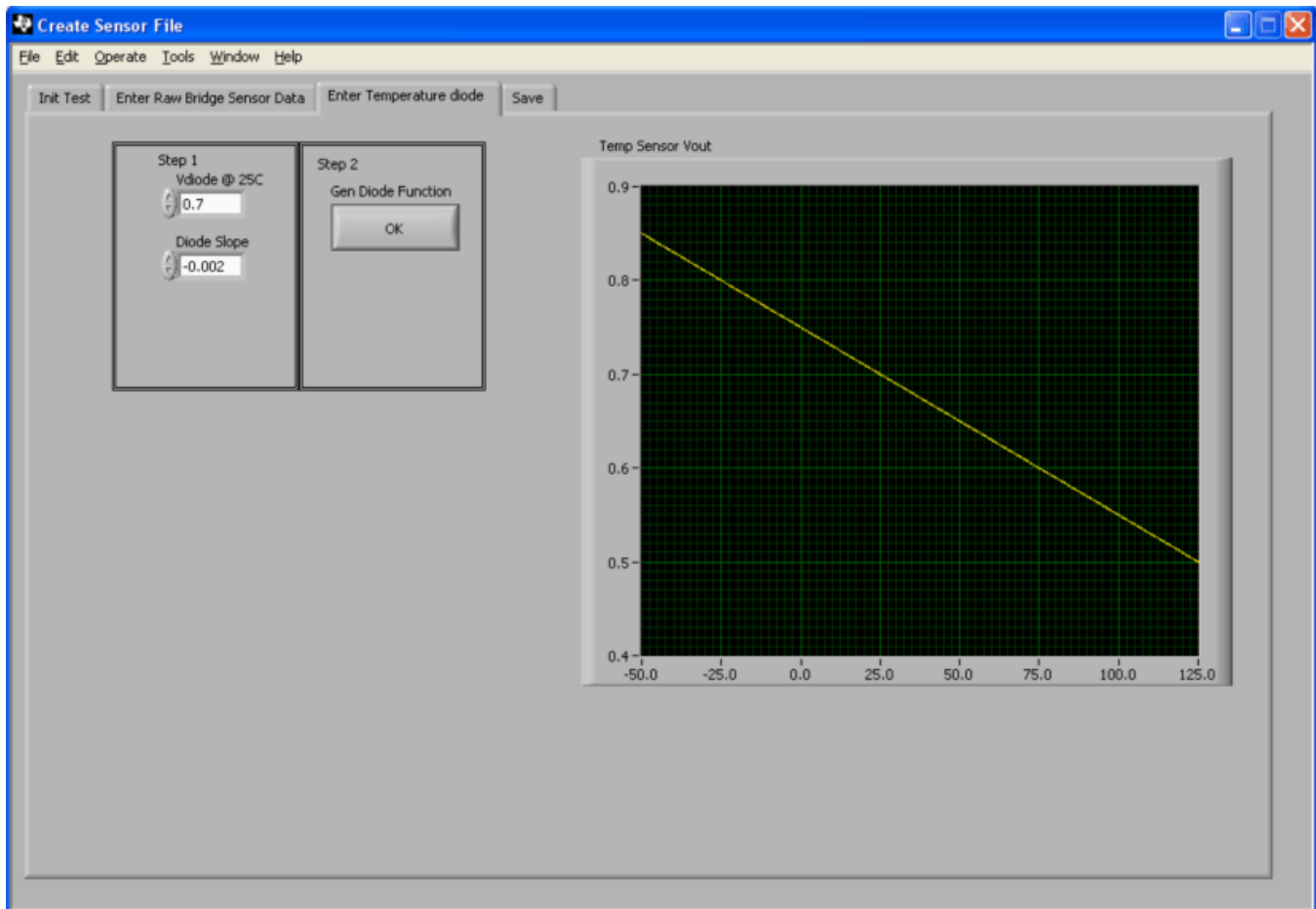

Figure 39. PGA309EVM-USB Software: Create Sensor Emulator File by Entering Temperature Data

There are two steps to this process.

Step 1. Set the diode voltage and the slope.

Enter the diode voltage at +25°C and the diode slope (typically $-2\text{mV}/^\circ\text{C}$).

Step 2. Press the Gen Diode Function **OK** button.

Press the button to complete this function.

The final step in the process of generating a sensor emulator file is to save the file. Figure 40 illustrates the Save tab. Note that the temperature function and sensor over temperature data are displayed for review.

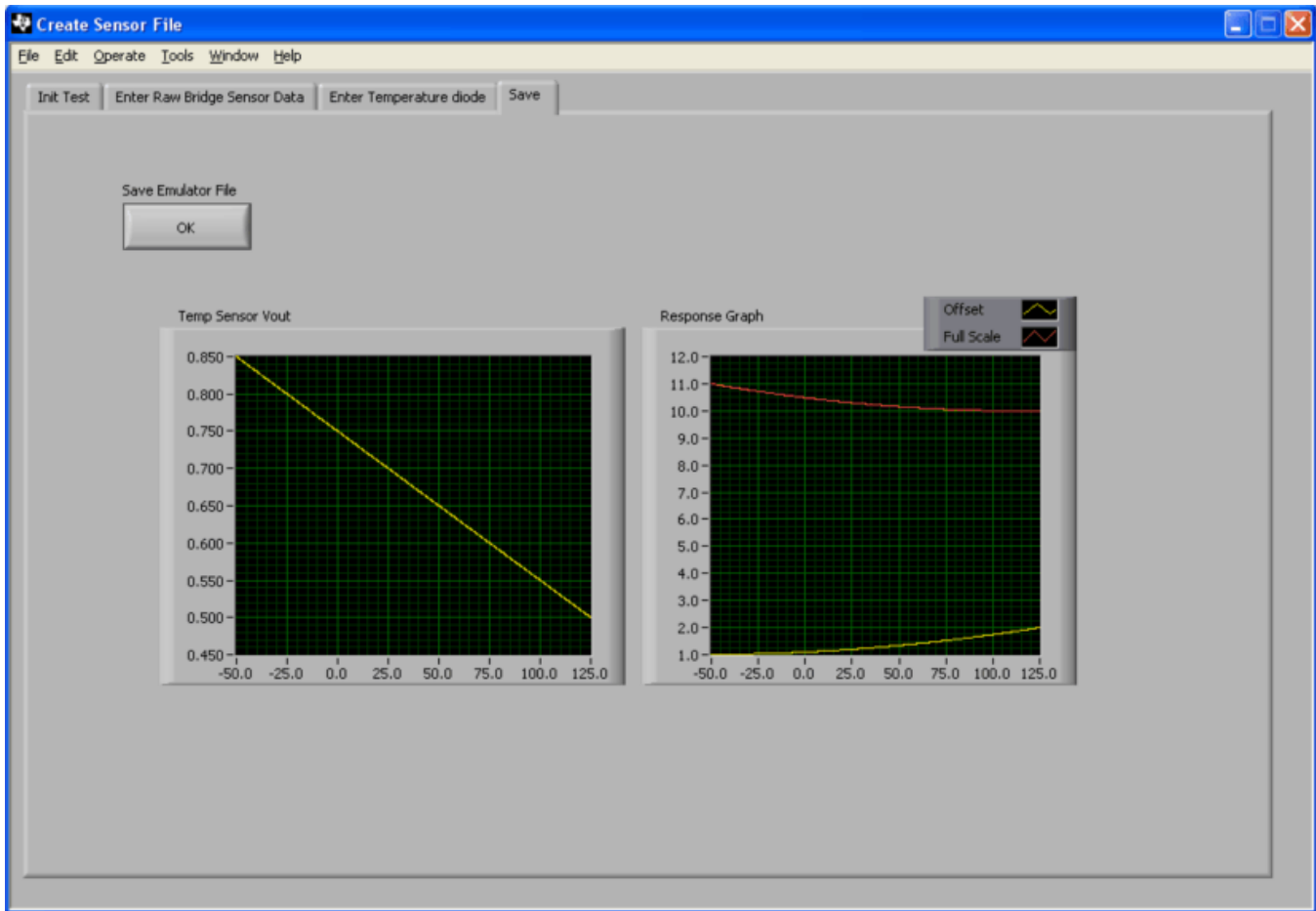

Figure 40. PGA309EVM-USB Software: Save a Created Sensor Emulator File

Revision History

NOTE: Page numbers for previous revisions may differ from page numbers in the current version.

Changes from A Revision (February, 2011) to B Revision	Page
• Changed list of included items in the <i>PGA309EVM-USB Hardware</i> section.	3
• Changed <i>Hardware Included with the PGA309EVM-USB</i> image.	3

STANDARD TERMS AND CONDITIONS FOR EVALUATION MODULES

1. *Delivery:* TI delivers TI evaluation boards, kits, or modules, including any accompanying demonstration software, components, or documentation (collectively, an "EVM" or "EVMs") to the User ("User") in accordance with the terms and conditions set forth herein. Acceptance of the EVM is expressly subject to the following terms and conditions.
 - 1.1 EVMs are intended solely for product or software developers for use in a research and development setting to facilitate feasibility evaluation, experimentation, or scientific analysis of TI semiconductor products. EVMs have no direct function and are not finished products. EVMs shall not be directly or indirectly assembled as a part or subassembly in any finished product. For clarification, any software or software tools provided with the EVM ("Software") shall not be subject to the terms and conditions set forth herein but rather shall be subject to the applicable terms and conditions that accompany such Software
 - 1.2 EVMs are not intended for consumer or household use. EVMs may not be sold, sublicensed, leased, rented, loaned, assigned, or otherwise distributed for commercial purposes by Users, in whole or in part, or used in any finished product or production system.
2. *Limited Warranty and Related Remedies/Disclaimers:*
 - 2.1 These terms and conditions do not apply to Software. The warranty, if any, for Software is covered in the applicable Software License Agreement.
 - 2.2 TI warrants that the TI EVM will conform to TI's published specifications for ninety (90) days after the date TI delivers such EVM to User. Notwithstanding the foregoing, TI shall not be liable for any defects that are caused by neglect, misuse or mistreatment by an entity other than TI, including improper installation or testing, or for any EVMs that have been altered or modified in any way by an entity other than TI. Moreover, TI shall not be liable for any defects that result from User's design, specifications or instructions for such EVMs. Testing and other quality control techniques are used to the extent TI deems necessary or as mandated by government requirements. TI does not test all parameters of each EVM.
 - 2.3 If any EVM fails to conform to the warranty set forth above, TI's sole liability shall be at its option to repair or replace such EVM, or credit User's account for such EVM. TI's liability under this warranty shall be limited to EVMs that are returned during the warranty period to the address designated by TI and that are determined by TI not to conform to such warranty. If TI elects to repair or replace such EVM, TI shall have a reasonable time to repair such EVM or provide replacements. Repaired EVMs shall be warranted for the remainder of the original warranty period. Replaced EVMs shall be warranted for a new full ninety (90) day warranty period.
3. *Regulatory Notices:*
 - 3.1 *United States*
 - 3.1.1 *Notice applicable to EVMs not FCC-Approved:*

This kit is designed to allow product developers to evaluate electronic components, circuitry, or software associated with the kit to determine whether to incorporate such items in a finished product and software developers to write software applications for use with the end product. This kit is not a finished product and when assembled may not be resold or otherwise marketed unless all required FCC equipment authorizations are first obtained. Operation is subject to the condition that this product not cause harmful interference to licensed radio stations and that this product accept harmful interference. Unless the assembled kit is designed to operate under part 15, part 18 or part 95 of this chapter, the operator of the kit must operate under the authority of an FCC license holder or must secure an experimental authorization under part 5 of this chapter.
 - 3.1.2 *For EVMs annotated as FCC – FEDERAL COMMUNICATIONS COMMISSION Part 15 Compliant:*

CAUTION

This device complies with part 15 of the FCC Rules. Operation is subject to the following two conditions: (1) This device may not cause harmful interference, and (2) this device must accept any interference received, including interference that may cause undesired operation.

Changes or modifications not expressly approved by the party responsible for compliance could void the user's authority to operate the equipment.

FCC Interference Statement for Class A EVM devices

NOTE: This equipment has been tested and found to comply with the limits for a Class A digital device, pursuant to part 15 of the FCC Rules. These limits are designed to provide reasonable protection against harmful interference when the equipment is operated in a commercial environment. This equipment generates, uses, and can radiate radio frequency energy and, if not installed and used in accordance with the instruction manual, may cause harmful interference to radio communications. Operation of this equipment in a residential area is likely to cause harmful interference in which case the user will be required to correct the interference at his own expense.

FCC Interference Statement for Class B EVM devices

NOTE: This equipment has been tested and found to comply with the limits for a Class B digital device, pursuant to part 15 of the FCC Rules. These limits are designed to provide reasonable protection against harmful interference in a residential installation. This equipment generates, uses and can radiate radio frequency energy and, if not installed and used in accordance with the instructions, may cause harmful interference to radio communications. However, there is no guarantee that interference will not occur in a particular installation. If this equipment does cause harmful interference to radio or television reception, which can be determined by turning the equipment off and on, the user is encouraged to try to correct the interference by one or more of the following measures:

- Reorient or relocate the receiving antenna.
- Increase the separation between the equipment and receiver.
- Connect the equipment into an outlet on a circuit different from that to which the receiver is connected.
- Consult the dealer or an experienced radio/TV technician for help.

3.2 Canada

3.2.1 For EVMs issued with an Industry Canada Certificate of Conformance to RSS-210

Concerning EVMs Including Radio Transmitters:

This device complies with Industry Canada license-exempt RSS standard(s). Operation is subject to the following two conditions: (1) this device may not cause interference, and (2) this device must accept any interference, including interference that may cause undesired operation of the device.

Concernant les EVMs avec appareils radio:

Le présent appareil est conforme aux CNR d'Industrie Canada applicables aux appareils radio exempts de licence. L'exploitation est autorisée aux deux conditions suivantes: (1) l'appareil ne doit pas produire de brouillage, et (2) l'utilisateur de l'appareil doit accepter tout brouillage radioélectrique subi, même si le brouillage est susceptible d'en compromettre le fonctionnement.

Concerning EVMs Including Detachable Antennas:

Under Industry Canada regulations, this radio transmitter may only operate using an antenna of a type and maximum (or lesser) gain approved for the transmitter by Industry Canada. To reduce potential radio interference to other users, the antenna type and its gain should be so chosen that the equivalent isotropically radiated power (e.i.r.p.) is not more than that necessary for successful communication. This radio transmitter has been approved by Industry Canada to operate with the antenna types listed in the user guide with the maximum permissible gain and required antenna impedance for each antenna type indicated. Antenna types not included in this list, having a gain greater than the maximum gain indicated for that type, are strictly prohibited for use with this device.

Concernant les EVMs avec antennes détachables

Conformément à la réglementation d'Industrie Canada, le présent émetteur radio peut fonctionner avec une antenne d'un type et d'un gain maximal (ou inférieur) approuvé pour l'émetteur par Industrie Canada. Dans le but de réduire les risques de brouillage radioélectrique à l'intention des autres utilisateurs, il faut choisir le type d'antenne et son gain de sorte que la puissance isotrope rayonnée équivalente (p.i.r.e.) ne dépasse pas l'intensité nécessaire à l'établissement d'une communication satisfaisante. Le présent émetteur radio a été approuvé par Industrie Canada pour fonctionner avec les types d'antenne énumérés dans le manuel d'usage et ayant un gain admissible maximal et l'impédance requise pour chaque type d'antenne. Les types d'antenne non inclus dans cette liste, ou dont le gain est supérieur au gain maximal indiqué, sont strictement interdits pour l'exploitation de l'émetteur.

3.3 Japan

3.3.1 *Notice for EVMs delivered in Japan:* Please see http://www.tij.co.jp/lstds/ti_ja/general/eStore/notice_01.page 日本国内に輸入される評価用キット、ボードについては、次のところをご覧ください。
http://www.tij.co.jp/lstds/ti_ja/general/eStore/notice_01.page

3.3.2 *Notice for Users of EVMs Considered "Radio Frequency Products" in Japan:* EVMs entering Japan may not be certified by TI as conforming to Technical Regulations of Radio Law of Japan.

If User uses EVMs in Japan, not certified to Technical Regulations of Radio Law of Japan, User is required by Radio Law of Japan to follow the instructions below with respect to EVMs:

1. Use EVMs in a shielded room or any other test facility as defined in the notification #173 issued by Ministry of Internal Affairs and Communications on March 28, 2006, based on Sub-section 1.1 of Article 6 of the Ministry's Rule for Enforcement of Radio Law of Japan,
2. Use EVMs only after User obtains the license of Test Radio Station as provided in Radio Law of Japan with respect to EVMs, or
3. Use of EVMs only after User obtains the Technical Regulations Conformity Certification as provided in Radio Law of Japan with respect to EVMs. Also, do not transfer EVMs, unless User gives the same notice above to the transferee. Please note that if User does not follow the instructions above, User will be subject to penalties of Radio Law of Japan.

【無線電波を送信する製品の開発キットをお使いになる際の注意事項】 開発キットの中には技術基準適合証明を受けていないものがあります。技術適合証明を受けていないもののご使用に際しては、電波法遵守のため、以下のいずれかの措置を取っていただく必要がありますのでご注意ください。

1. 電波法施行規則第6条第1項第1号に基づく平成18年3月28日総務省告示第173号で定められた電波暗室等の試験設備でご使用いただく。
2. 実験局の免許を取得後ご使用いただく。
3. 技術基準適合証明を取得後ご使用いただく。

なお、本製品は、上記の「ご使用にあたっての注意」を譲渡先、移転先に通知しない限り、譲渡、移転できないものとします。

上記を遵守頂けない場合は、電波法の罰則が適用される可能性があることをご留意ください。日本テキサス・インスツルメンツ株式会社
東京都新宿区西新宿 6 丁目 2 4 番 1 号
西新宿三井ビル

3.3.3 *Notice for EVMs for Power Line Communication:* Please see http://www.tij.co.jp/llds/ti_ja/general/eStore/notice_02.page
電力線搬送波通信についての開発キットをお使いになる際の注意事項については、次のところをご覧ください。http://www.tij.co.jp/llds/ti_ja/general/eStore/notice_02.page

4 *EVM Use Restrictions and Warnings:*

4.1 EVMS ARE NOT FOR USE IN FUNCTIONAL SAFETY AND/OR SAFETY CRITICAL EVALUATIONS, INCLUDING BUT NOT LIMITED TO EVALUATIONS OF LIFE SUPPORT APPLICATIONS.

4.2 User must read and apply the user guide and other available documentation provided by TI regarding the EVM prior to handling or using the EVM, including without limitation any warning or restriction notices. The notices contain important safety information related to, for example, temperatures and voltages.

4.3 *Safety-Related Warnings and Restrictions:*

4.3.1 User shall operate the EVM within TI's recommended specifications and environmental considerations stated in the user guide, other available documentation provided by TI, and any other applicable requirements and employ reasonable and customary safeguards. Exceeding the specified performance ratings and specifications (including but not limited to input and output voltage, current, power, and environmental ranges) for the EVM may cause personal injury or death, or property damage. If there are questions concerning performance ratings and specifications, User should contact a TI field representative prior to connecting interface electronics including input power and intended loads. Any loads applied outside of the specified output range may also result in unintended and/or inaccurate operation and/or possible permanent damage to the EVM and/or interface electronics. Please consult the EVM user guide prior to connecting any load to the EVM output. If there is uncertainty as to the load specification, please contact a TI field representative. During normal operation, even with the inputs and outputs kept within the specified allowable ranges, some circuit components may have elevated case temperatures. These components include but are not limited to linear regulators, switching transistors, pass transistors, current sense resistors, and heat sinks, which can be identified using the information in the associated documentation. When working with the EVM, please be aware that the EVM may become very warm.

4.3.2 EVMs are intended solely for use by technically qualified, professional electronics experts who are familiar with the dangers and application risks associated with handling electrical mechanical components, systems, and subsystems. User assumes all responsibility and liability for proper and safe handling and use of the EVM by User or its employees, affiliates, contractors or designees. User assumes all responsibility and liability to ensure that any interfaces (electronic and/or mechanical) between the EVM and any human body are designed with suitable isolation and means to safely limit accessible leakage currents to minimize the risk of electrical shock hazard. User assumes all responsibility and liability for any improper or unsafe handling or use of the EVM by User or its employees, affiliates, contractors or designees.

4.4 User assumes all responsibility and liability to determine whether the EVM is subject to any applicable international, federal, state, or local laws and regulations related to User's handling and use of the EVM and, if applicable, User assumes all responsibility and liability for compliance in all respects with such laws and regulations. User assumes all responsibility and liability for proper disposal and recycling of the EVM consistent with all applicable international, federal, state, and local requirements.

5. *Accuracy of Information:* To the extent TI provides information on the availability and function of EVMs, TI attempts to be as accurate as possible. However, TI does not warrant the accuracy of EVM descriptions, EVM availability or other information on its websites as accurate, complete, reliable, current, or error-free.

6. *Disclaimers:*

6.1 EXCEPT AS SET FORTH ABOVE, EVMS AND ANY WRITTEN DESIGN MATERIALS PROVIDED WITH THE EVM (AND THE DESIGN OF THE EVM ITSELF) ARE PROVIDED "AS IS" AND "WITH ALL FAULTS." TI DISCLAIMS ALL OTHER WARRANTIES, EXPRESS OR IMPLIED, REGARDING SUCH ITEMS, INCLUDING BUT NOT LIMITED TO ANY IMPLIED WARRANTIES OF MERCHANTABILITY OR FITNESS FOR A PARTICULAR PURPOSE OR NON-INFRINGEMENT OF ANY THIRD PARTY PATENTS, COPYRIGHTS, TRADE SECRETS OR OTHER INTELLECTUAL PROPERTY RIGHTS.

6.2 EXCEPT FOR THE LIMITED RIGHT TO USE THE EVM SET FORTH HEREIN, NOTHING IN THESE TERMS AND CONDITIONS SHALL BE CONSTRUED AS GRANTING OR CONFERRING ANY RIGHTS BY LICENSE, PATENT, OR ANY OTHER INDUSTRIAL OR INTELLECTUAL PROPERTY RIGHT OF TI, ITS SUPPLIERS/LICENSORS OR ANY OTHER THIRD PARTY, TO USE THE EVM IN ANY FINISHED END-USER OR READY-TO-USE FINAL PRODUCT, OR FOR ANY INVENTION, DISCOVERY OR IMPROVEMENT MADE, CONCEIVED OR ACQUIRED PRIOR TO OR AFTER DELIVERY OF THE EVM.

7. *USER'S INDEMNITY OBLIGATIONS AND REPRESENTATIONS.* USER WILL DEFEND, INDEMNIFY AND HOLD TI, ITS LICENSORS AND THEIR REPRESENTATIVES HARMLESS FROM AND AGAINST ANY AND ALL CLAIMS, DAMAGES, LOSSES, EXPENSES, COSTS AND LIABILITIES (COLLECTIVELY, "CLAIMS") ARISING OUT OF OR IN CONNECTION WITH ANY HANDLING OR USE OF THE EVM THAT IS NOT IN ACCORDANCE WITH THESE TERMS AND CONDITIONS. THIS OBLIGATION SHALL APPLY WHETHER CLAIMS ARISE UNDER STATUTE, REGULATION, OR THE LAW OF TORT, CONTRACT OR ANY OTHER LEGAL THEORY, AND EVEN IF THE EVM FAILS TO PERFORM AS DESCRIBED OR EXPECTED.

8. *Limitations on Damages and Liability:*

8.1 *General Limitations.* IN NO EVENT SHALL TI BE LIABLE FOR ANY SPECIAL, COLLATERAL, INDIRECT, PUNITIVE, INCIDENTAL, CONSEQUENTIAL, OR EXEMPLARY DAMAGES IN CONNECTION WITH OR ARISING OUT OF THESE TERMS AND CONDITIONS OR THE USE OF THE EVMS PROVIDED HEREUNDER, REGARDLESS OF WHETHER TI HAS BEEN ADVISED OF THE POSSIBILITY OF SUCH DAMAGES. EXCLUDED DAMAGES INCLUDE, BUT ARE NOT LIMITED TO, COST OF REMOVAL OR REINSTALLATION, ANCILLARY COSTS TO THE PROCUREMENT OF SUBSTITUTE GOODS OR SERVICES, RETESTING, OUTSIDE COMPUTER TIME, LABOR COSTS, LOSS OF GOODWILL, LOSS OF PROFITS, LOSS OF SAVINGS, LOSS OF USE, LOSS OF DATA, OR BUSINESS INTERRUPTION. NO CLAIM, SUIT OR ACTION SHALL BE BROUGHT AGAINST TI MORE THAN ONE YEAR AFTER THE RELATED CAUSE OF ACTION HAS OCCURRED.

8.2 *Specific Limitations.* IN NO EVENT SHALL TI'S AGGREGATE LIABILITY FROM ANY WARRANTY OR OTHER OBLIGATION ARISING OUT OF OR IN CONNECTION WITH THESE TERMS AND CONDITIONS, OR ANY USE OF ANY TI EVM PROVIDED HEREUNDER, EXCEED THE TOTAL AMOUNT PAID TO TI FOR THE PARTICULAR UNITS SOLD UNDER THESE TERMS AND CONDITIONS WITH RESPECT TO WHICH LOSSES OR DAMAGES ARE CLAIMED. THE EXISTENCE OF MORE THAN ONE CLAIM AGAINST THE PARTICULAR UNITS SOLD TO USER UNDER THESE TERMS AND CONDITIONS SHALL NOT ENLARGE OR EXTEND THIS LIMIT.

9. *Return Policy.* Except as otherwise provided, TI does not offer any refunds, returns, or exchanges. Furthermore, no return of EVM(s) will be accepted if the package has been opened and no return of the EVM(s) will be accepted if they are damaged or otherwise not in a resalable condition. If User feels it has been incorrectly charged for the EVM(s) it ordered or that delivery violates the applicable order, User should contact TI. All refunds will be made in full within thirty (30) working days from the return of the components(s), excluding any postage or packaging costs.

10. *Governing Law:* These terms and conditions shall be governed by and interpreted in accordance with the laws of the State of Texas, without reference to conflict-of-laws principles. User agrees that non-exclusive jurisdiction for any dispute arising out of or relating to these terms and conditions lies within courts located in the State of Texas and consents to venue in Dallas County, Texas. Notwithstanding the foregoing, any judgment may be enforced in any United States or foreign court, and TI may seek injunctive relief in any United States or foreign court.

IMPORTANT NOTICE

Texas Instruments Incorporated and its subsidiaries (TI) reserve the right to make corrections, enhancements, improvements and other changes to its semiconductor products and services per JESD46, latest issue, and to discontinue any product or service per JESD48, latest issue. Buyers should obtain the latest relevant information before placing orders and should verify that such information is current and complete. All semiconductor products (also referred to herein as "components") are sold subject to TI's terms and conditions of sale supplied at the time of order acknowledgment.

TI warrants performance of its components to the specifications applicable at the time of sale, in accordance with the warranty in TI's terms and conditions of sale of semiconductor products. Testing and other quality control techniques are used to the extent TI deems necessary to support this warranty. Except where mandated by applicable law, testing of all parameters of each component is not necessarily performed.

TI assumes no liability for applications assistance or the design of Buyers' products. Buyers are responsible for their products and applications using TI components. To minimize the risks associated with Buyers' products and applications, Buyers should provide adequate design and operating safeguards.

TI does not warrant or represent that any license, either express or implied, is granted under any patent right, copyright, mask work right, or other intellectual property right relating to any combination, machine, or process in which TI components or services are used. Information published by TI regarding third-party products or services does not constitute a license to use such products or services or a warranty or endorsement thereof. Use of such information may require a license from a third party under the patents or other intellectual property of the third party, or a license from TI under the patents or other intellectual property of TI.

Reproduction of significant portions of TI information in TI data books or data sheets is permissible only if reproduction is without alteration and is accompanied by all associated warranties, conditions, limitations, and notices. TI is not responsible or liable for such altered documentation. Information of third parties may be subject to additional restrictions.

Resale of TI components or services with statements different from or beyond the parameters stated by TI for that component or service voids all express and any implied warranties for the associated TI component or service and is an unfair and deceptive business practice. TI is not responsible or liable for any such statements.

Buyer acknowledges and agrees that it is solely responsible for compliance with all legal, regulatory and safety-related requirements concerning its products, and any use of TI components in its applications, notwithstanding any applications-related information or support that may be provided by TI. Buyer represents and agrees that it has all the necessary expertise to create and implement safeguards which anticipate dangerous consequences of failures, monitor failures and their consequences, lessen the likelihood of failures that might cause harm and take appropriate remedial actions. Buyer will fully indemnify TI and its representatives against any damages arising out of the use of any TI components in safety-critical applications.

In some cases, TI components may be promoted specifically to facilitate safety-related applications. With such components, TI's goal is to help enable customers to design and create their own end-product solutions that meet applicable functional safety standards and requirements. Nonetheless, such components are subject to these terms.

No TI components are authorized for use in FDA Class III (or similar life-critical medical equipment) unless authorized officers of the parties have executed a special agreement specifically governing such use.

Only those TI components which TI has specifically designated as military grade or "enhanced plastic" are designed and intended for use in military/aerospace applications or environments. Buyer acknowledges and agrees that any military or aerospace use of TI components which have **not** been so designated is solely at the Buyer's risk, and that Buyer is solely responsible for compliance with all legal and regulatory requirements in connection with such use.

TI has specifically designated certain components as meeting ISO/TS16949 requirements, mainly for automotive use. In any case of use of non-designated products, TI will not be responsible for any failure to meet ISO/TS16949.

Products

Audio	www.ti.com/audio
Amplifiers	amplifier.ti.com
Data Converters	dataconverter.ti.com
DLP® Products	www.dlp.com
DSP	dsp.ti.com
Clocks and Timers	www.ti.com/clocks
Interface	interface.ti.com
Logic	logic.ti.com
Power Mgmt	power.ti.com
Microcontrollers	microcontroller.ti.com
RFID	www.ti-rfid.com
OMAP Applications Processors	www.ti.com/omap
Wireless Connectivity	www.ti.com/wirelessconnectivity

Applications

Automotive and Transportation	www.ti.com/automotive
Communications and Telecom	www.ti.com/communications
Computers and Peripherals	www.ti.com/computers
Consumer Electronics	www.ti.com/consumer-apps
Energy and Lighting	www.ti.com/energy
Industrial	www.ti.com/industrial
Medical	www.ti.com/medical
Security	www.ti.com/security
Space, Avionics and Defense	www.ti.com/space-avionics-defense
Video and Imaging	www.ti.com/video

TI E2E Community

e2e.ti.com