

REVISIONS					
REV	ECO	DESCRIPTION	DATE	BY	APPR
A1	--	RELEASED DRAWING	Dec-26-2016	Ben	Tommy
A2	--	UPDATE NOTES	Jul-04-2017	Nick	Tommy
A3	--	UPDATE DRAWING	Mar-20-2018	White	Tommy

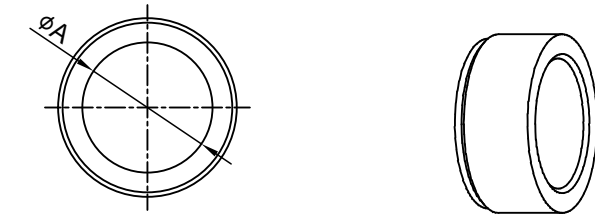
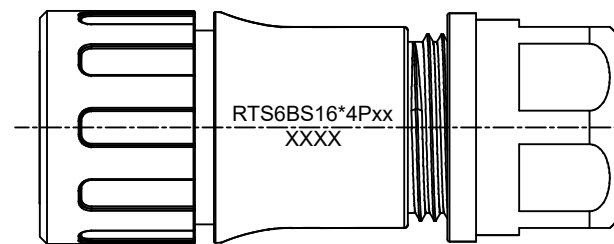
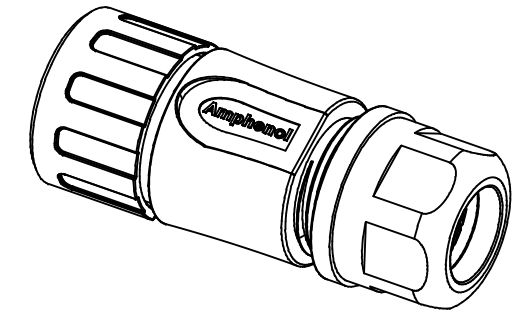
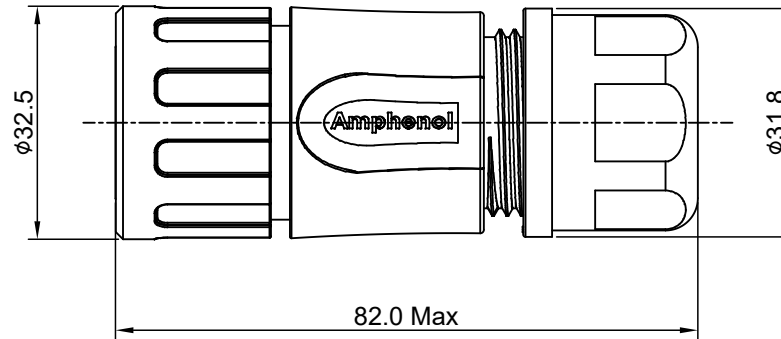
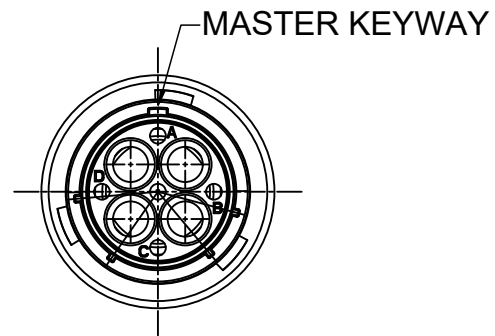

NOTES : (UNLESS OTHERWISE SPECIFIED)

1. MATERIAL :
 - SHELL : THERMOPLASTIC , UL94 V-0.
 - INSERT : THERMOPLASTIC , UL94 V-0.
 - COUPLING NUT : THERMOPLASTIC , UL94 V-0.
 - O-RING : NBR/SILICONE RUBBER.
 - WASHER: SILICONE RUBBER.
 - BACK SHELL : THERMOPLASTIC , UL94 V-0.
 - CLAMP NUT : THERMOPLASTIC , UL94 V-0.
 - CLAMP RING : THERMOPLASTIC , UL94 V-0.
 - CABLE SEAL : EPDM.
2. SPECIFICATIONS :
 - 2.1 RATED CURRENT : 45A (MAX) .
 - 2.2 RATED VOLTAGE : 500V(AC/DC).
 - 2.3 OPERATING TEMPERATURE : SEE TABLE .
 - 2.4 DIELECTRIC WITHSTANDING VOLTAGE : LESS THAN 2 MILLIAMPS CURRENT LEAKAGE@2000 VOLTS AC.
 - 2.5 INSULATION RESISTANCE : 5000 MEGOHMS MIN.
 - 2.6 IP--CLASS : IP67 AND IP69K IN THE MATED CONDITION.
 - 2.7 MATING CYCLES DURABILITY : 500 CYCLES MIN.
 - 2.8 RoHS COMPLIANT.
3. SUITABLE CONTACTS : 8# CONTACT.
4. ALL DIMENSIONS ARE FOR REFERENCE USE ONLY.

DIMENSION ϕA	CABLE OD RANGE
14.5 MM	10.0-14.0 MM
17.5 MM	13.5-17.0 MM

KEY	PART NUMBER	
		-40°C ~ +105°C
N	RTS6BS16N4P	RTS6BS16N4P03

QUANTITY	PART NUMBER	DESCRIPTION	ITEM												
MATERIALS LIST															
UNLESS OTHERWISE SPECIFIED 1) All dimensions are in metric(mm). 2) Tolerances are as follows: 1 PL DEC ± 0.30 Fractions $\pm 1/64$ 2 PL DEC ± 0.15 Angles $\pm 1^\circ$ 3 PL DEC ± 0.08 3) Note reference =		<table border="1"> <thead> <tr> <th>SIGNATURES</th> <th>DATE</th> </tr> </thead> <tbody> <tr> <td>DRAWN: White</td> <td>Mar-20-2018</td> </tr> <tr> <td>CHECKED: Tod</td> <td>Mar-20-2018</td> </tr> <tr> <td>ENGINEER:</td> <td></td> </tr> <tr> <td>APPROVAL: Tommy</td> <td>Mar-20-2018</td> </tr> </tbody> </table>		SIGNATURES	DATE	DRAWN: White	Mar-20-2018	CHECKED: Tod	Mar-20-2018	ENGINEER:		APPROVAL: Tommy	Mar-20-2018		
SIGNATURES	DATE														
DRAWN: White	Mar-20-2018														
CHECKED: Tod	Mar-20-2018														
ENGINEER:															
APPROVAL: Tommy	Mar-20-2018														
MATERIAL SPECIFICATIONS:		<p style="text-align: center;">Amphenol</p> <p>Sine Systems - www.amphenol-sine.com 44724 Morley Drive Clinton Township, MI 48036</p>													
PROCESS SPECIFICATIONS:		<p>ECO-MATE, PLUG, BACK SHELL, SIZE 16,4POS,PIN.</p>													
NEXT ASSY:		<table border="1"> <tr> <td>SIZE</td> <td>TYPE</td> <td>DWG NO:</td> <td>REVISION</td> </tr> <tr> <td>B</td> <td>C-</td> <td>RTS6BS16*4Pxx</td> <td>A3</td> </tr> <tr> <td colspan="2">SCALE: NONE</td> <td colspan="2">SHEET 1 OF 1</td> </tr> </table>		SIZE	TYPE	DWG NO:	REVISION	B	C-	RTS6BS16*4Pxx	A3	SCALE: NONE		SHEET 1 OF 1	
SIZE	TYPE	DWG NO:	REVISION												
B	C-	RTS6BS16*4Pxx	A3												
SCALE: NONE		SHEET 1 OF 1													

TITLE: ECO-MATE PLUG BACK SHELL SIZE 16,4POS,PIN. DWG NO: RTS6BS16*4Pxx REV: A3 SH: 1 OF: 1

ecomate® RM/RSSM/Aquarius™ - Contact Size 3.6mm (1604 Insert Arrangement) Options

Crimp Contacts, 1604 Insert Arrangement, Machined					
Part Number		AWG	Wire Range (mm ²)	For Use w Endcap	Plating
Male	Female				
MP10A23T	MS10A23T	12-10	3.0 - 6.0	Yes	Tin
MP10A23S	MS10A23S	12-10	3.0 - 6.0	Yes	Silver
MP10A23F	MS10A23F	12-10	3.0 - 6.0	Yes	Gold Flash
MP10A23G5	MS10A23G5	12-10	3.0 - 6.0	Yes	Gold 5μ"
MP10S23G10	MS10A23G10	12-10	3.0 - 6.0	Yes	Gold 10μ"
MP10A23G15	MS10A23G15	12-10	3.0 - 6.0	Yes	Gold 15μ"
MS10A23G30	MS10A23G30	12-10	3.0 - 6.0	Yes	Gold 30μ"

Tooling, Machined	
Part Number	Description
QXRT08	Contact Extraction Tool, # 8 (Ø 3.6mm) Contact
M300BT	Hand Crimper
WA27-300BT-EP	Pneumatic Crimper
TP968	Locator M3200BT and WA27-300BT-EP

Plating Options	
Symbol	Plating
T	Tin Plating Over Nickel
S	Silver Plating Over Nickel
F	Gold Plated
G5	Gold Plated (Thickness 5μ")
G10	Gold Plated (Thickness 10μ")
G15	Gold Plated (Thickness 15μ")
G30	Gold Plated (Thickness 30μ")