

REVISIONS				
REV	ECO	DESCRIPTION	DATE	BY APPR
A1	-	RELEASED DRAWING	Nov-9-17	Rookie Tommy
A2	-	ADD THE GS PART NUMBER	Jan-28-19	Blink Tommy
A3	-	CHANGE HAND CRIMPER	Nov-8-19	Flan Tommy

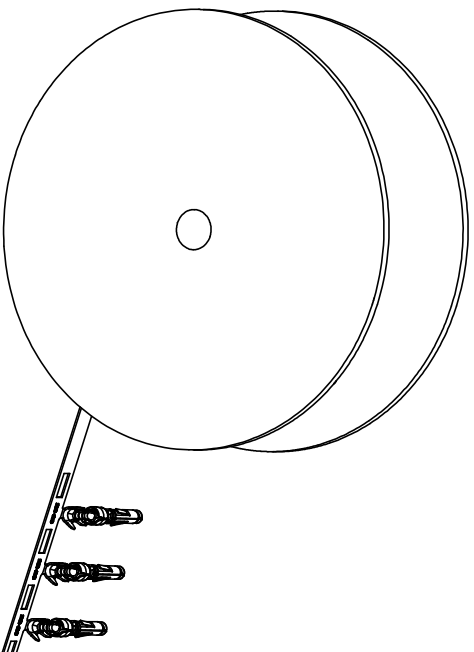

CONTACT ORIENTATION ON ROLL

NOTES: (UNLESS OTHERWISE SPECIFIED)

- MATERIAL:
  - CONTACT BODY: COPPER ALLOY.
  - OUTER SPRING: STAINLESS STEEL.
- SPECIFICATIONS:
  - CURRENT RATING: 5A MAX.
  - TERMINATION TYPE: CRIMPING.
  - WIRE RANGE: 22~20AWG.
  - WIRE INSULATION DIA(MAX):  $\varnothing 2.6\text{mm}$ .
- RHS COMPLIANT.
- ALL DIMENSIONS ARE FOR REFERENCE USE ONLY.
- AVAILABLE TOOLS:
  - HAND CRIMPER: MFX-3958. A3
  - CRIMP APPLICATOR: MFX-3957.
  - EXTRACTION TOOL: QXRT20.

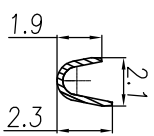
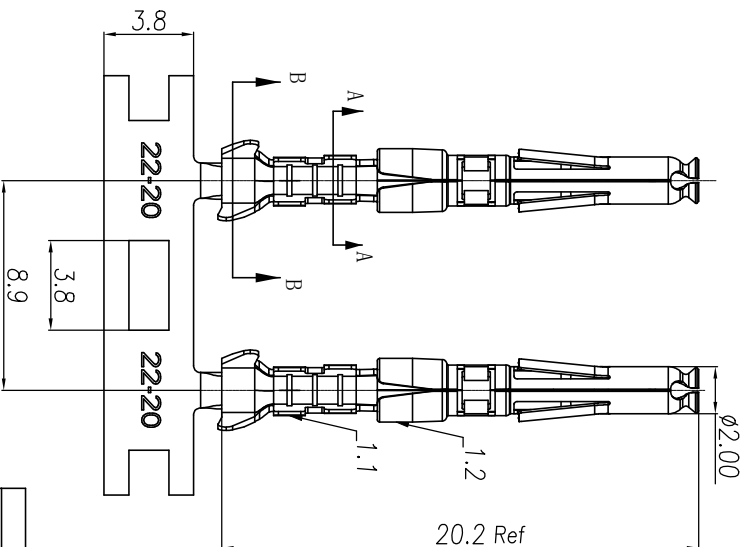

SECTION A-A

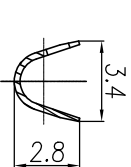

SECTION B-B

QUANTITY	PART NUMBER	DESCRIPTION	ITER

**MATERIALS LIST**

UNLESS OTHERWISE SPECIFIED			
1) All dimensions are in millimeters.	DRAWN:	RAI	Nov-8-19
2) Tolerances are as follows:	CHECKED:	RAI	Nov-8-19
1 Pt. DEC 20-09	ENGINEER:	Tommy	Nov-8-19
3 Pt. DEC 20-08	APPROVE:	Tommy	Nov-8-19
3) Note reference =	CUSTOMER:		

MATERIAL SPECIFICATIONS		PROCESS SPECIFICATIONS	

NEXT ASBY			

SCALE	TYPE	SIZE	REVISION
NONE	B	C-	A3

ECO-MATE SOCKET CONTACT,  
STAMPED, 20-22AWG, SIZE 20

**Amphenol**

Sine Systems - www.amphenol-sine.com  
44724 Monty Drive  
Clinton Township, MI 48038

P/N	CONTACT PLATING(MATING AREA)
SS20W2T	TIN PLATING OVER NICKEL.
SS20W2N	NICKEL PLATING OVER COPPERIZE.
SS20W2F	GOLD FLASH PLATING OVER NICKEL.
SS20W2G5	5 $\mu$ " GOLD PLATING OVER NICKEL.
SS20W2G10	10 $\mu$ " GOLD PLATING OVER NICKEL.
SS20W2G15	15 $\mu$ " GOLD PLATING OVER NICKEL.
SS20W2G30	30 $\mu$ " GOLD PLATING OVER NICKEL.

A2