

| REVISIONS | | | | | |
|-----------|-----|---------------|-------------|-------|-------|
| REV | ECO | DESCRIPTION | DATE | BY | APPR |
| A1 | - | FIRST RELEASE | Jan.12,2018 | White | Tommy |

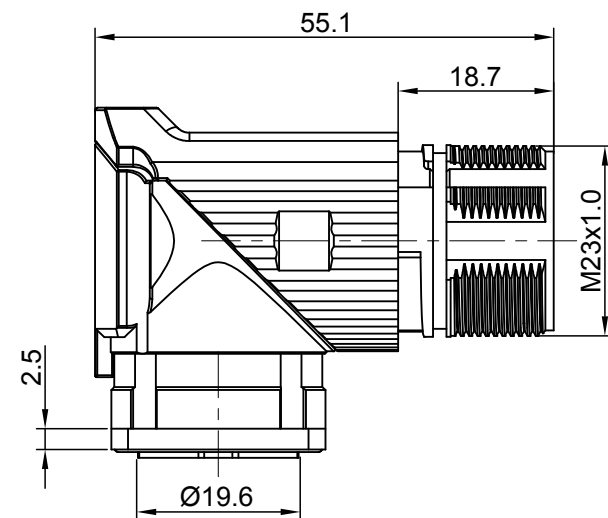

P type, Normal Key

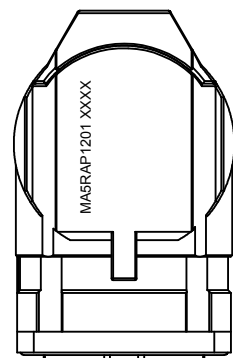
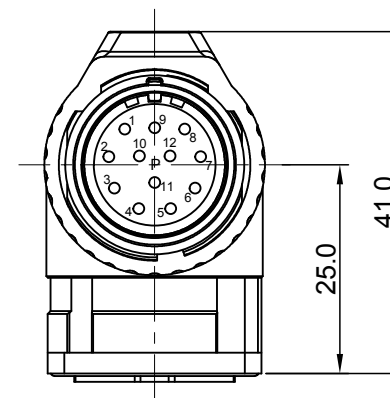

NOTES: UNLESS OTHERWISE SPECIFIED

- MATERIAL:
 - INSULATION INSERT: PA66,UL94 V0
 - SEAL: VITON
 - HOUSING BODY: ZINC DIE CAST, NICKEL PLATED
 - CONTACT: COPPER ALLOY, GOLD PLATED
- SPECIFICATIONS:
 - 2.1 CURRENT RATING: 10 AMPS
 - 2.2 VOLTAGE RATING: 160 V AC/DC
 - 2.3 OPERATING TEMPERATURE: -20°C TO +130°C
 - 2.4 DIELECTRIC WITHSTANDING VOLTAGE: LESS THAN 2 MILLIAMPS CURRENT LEAKAGE @ 2500 VOLTS AC.
 - 2.5 DEGREE OF PROTECTION: IP67 (MATED CONDITION)
 - 2.6 DEGREE OF POLLUTION: 3 PER UL840
 - 2.7 OVERVOLTAGE CATEGORY: III PER UL840
 - 2.8 MATING CYCLE DURABILITY: >500 CYCLES
 - 2.9 RoHS COMPLIANT
- ALL DIMENSIONS ARE FOR REFERENCE USE ONLY.

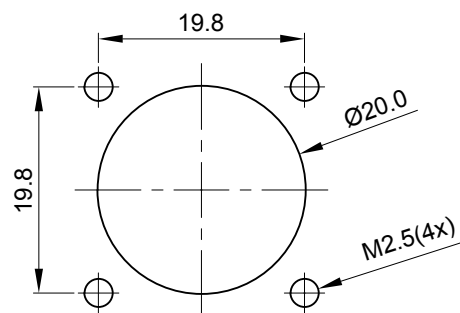

MOUNTING HOLE

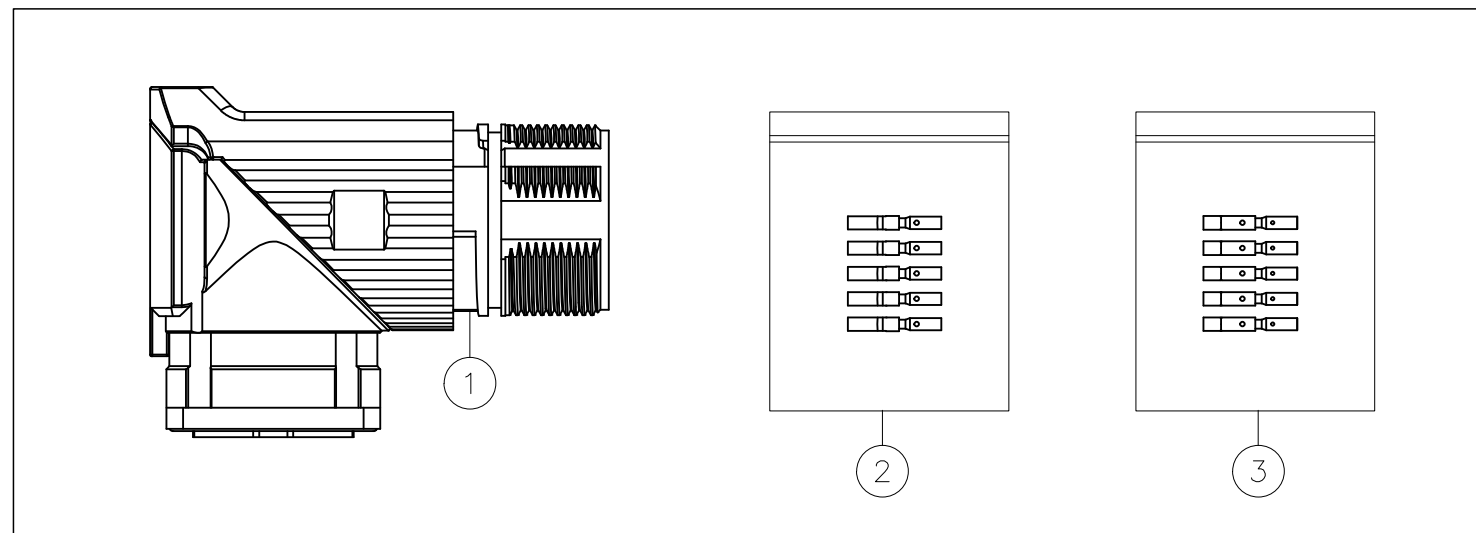
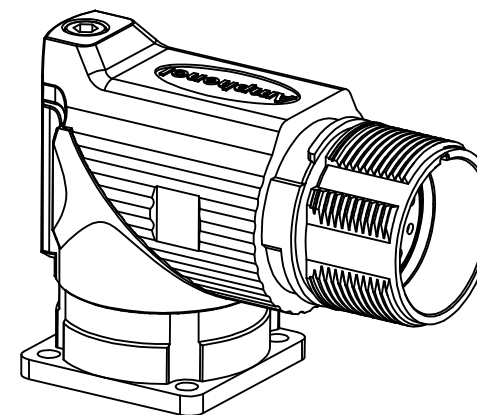
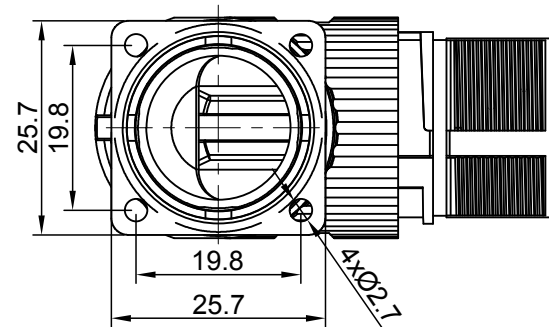

| QUANTITY | PART NUMBER | DESCRIPTION | ITEM |
|----------|-------------|--|------|
| 12 | SC000030 | CONTACT, SOCKET, Ø1.0mm,CRIMP 24~28AWG | 3 |
| 12 | SC000044 | CONTACT, SOCKET, Ø1.0mm,CRIMP 18~22AWG | 2 |
| 1 | MA5RAP1201 | CONNECTOR | 1 |

| MATERIALS LIST | | | |
|--|-------|-----------------|----------|
| SIGNATURES | | DATE | |
| DRAWN: | White | Jan.12.2018 | |
| CHECKED: | Tod | Jan.12.2018 | |
| ENGINEER: | | | |
| APPROVAL: | Tommy | Jan.12.2018 | |
| CUSTOMER: | | | |
| THIS DRAWING IS SUPPLIED FOR INFORMATION ONLY. DESIGN FEATURES, SPECIFICATIONS AND PERFORMANCE DATA SHOWN HEREON ARE THE PROPERTY OF THE AMPHENOL CORPORATION. NO RIGHTS OF REPRODUCTION ARE IMPLIED. ALL DIMENSIONS ARE SUBJECT TO NORMAL MANUFACTURING VARIATIONS. | | | |
| SIZE | TYPE | DWG NO: | REVISION |
| B | C- | MA5RAP1201S-KIT | A1 |
| SCALE: NONE | | SHEET 1 OF 1 | |

TITLE: KIT,M23A,REC.,RA,12P,P TYPE,CHECKMATE

DWG NO: MA5RAP1201S-KIT

REV: A1

SH: 1

OF: 1