

# 1EDI EiceDRIVER™ Compact

## Output with Clamp variant for IGBT

Single Channel IGBT Gate Driver IC

1EDI10I12MF

1EDI20I12MF

1EDI30I12MF

## Data Sheet

Rev. 2.0, 2014-11-10

**Edition 2014-11-10**

**Published by  
Infineon Technologies AG  
81726 Munich, Germany**

**© 2014 Infineon Technologies AG  
All Rights Reserved.**

### **Legal Disclaimer**

The information given in this document shall in no event be regarded as a guarantee of conditions or characteristics. With respect to any examples or hints given herein, any typical values stated herein and/or any information regarding the application of the device, Infineon Technologies hereby disclaims any and all warranties and liabilities of any kind, including without limitation, warranties of non-infringement of intellectual property rights of any third party.

### **Information**

For further information on technology, delivery terms and conditions and prices, please contact the nearest Infineon Technologies Office ([www.infineon.com](http://www.infineon.com)).

### **Warnings**

Due to technical requirements, components may contain dangerous substances. For information on the types in question, please contact the nearest Infineon Technologies Office.

Infineon Technologies components may be used in life-support devices or systems only with the express written approval of Infineon Technologies, if a failure of such components can reasonably be expected to cause the failure of that life-support device or system or to affect the safety or effectiveness of that device or system. Life support devices or systems are intended to be implanted in the human body or to support and/or maintain and sustain and/or protect human life. If they fail, it is reasonable to assume that the health of the user or other persons may be endangered.

**Revision History**

Page or Item	Subjects (major changes since previous revision)
<b>Rev. 2.0, 2014-11-10</b>	
all pages	Final datasheet, parameter completion and editorial changes
<b>Rev. 1.02, 2014-10-14</b>	
all pages	parameter completion

**Trademarks of Infineon Technologies AG**

AURIX™, BlueMoon™, C166™, CanPAK™, CIPOS™, CIPURSE™, COMNEON™, EconoPACK™, CoolMOS™, CoolSET™, CORECONTROL™, CROSSAVE™, DAVE™, EasyPIM™, EconoBRIDGE™, EconoDUAL™, EconoPIM™, EiceDRIVER™, eupec™, FCOS™, HITFET™, HybridPACK™, I<sup>2</sup>RF™, ISOFACE™, IsoPACK™, MIPAQ™, ModSTACK™, my-d™, NovalithIC™, OmniTune™, OptiMOS™, ORIGA™, PRIMARION™, PrimePACK™, PrimeSTACK™, PRO-SIL™, PROFET™, RASIC™, ReverSave™, SatRIC™, SIEGET™, SINDRION™, SIPMOS™, SMARTi™, SmartLEWIS™, SOLID FLASH™, TEMPFET™, thinQ!™, TRENCHSTOP™, TriCore™, X-GOLD™, X-PMU™, XMM™, XPOSSYS™.

**Other Trademarks**

Advance Design System™ (ADS) of Agilent Technologies, AMBA™, ARM™, MULTI-ICE™, KEIL™, PRIMECELL™, REALVIEW™, THUMB™, μVision™ of ARM Limited, UK. AUTOSAR™ is licensed by AUTOSAR development partnership. Bluetooth™ of Bluetooth SIG Inc. CAT-iq™ of DECT Forum. COLOSSUS™, FirstGPS™ of Trimble Navigation Ltd. EMV™ of EMVCo, LLC (Visa Holdings Inc.). EPCOS™ of Epcos AG. FLEXGO™ of Microsoft Corporation. FlexRay™ is licensed by FlexRay Consortium. HYPERTERMINAL™ of Hilgraeve Incorporated. IEC™ of Commission Electrotechnique Internationale. IrDA™ of Infrared Data Association Corporation. ISO™ of INTERNATIONAL ORGANIZATION FOR STANDARDIZATION. MATLAB™ of MathWorks, Inc. MAXIM™ of Maxim Integrated Products, Inc. MICROTEC™, NUCLEUS™ of Mentor Graphics Corporation. Mifare™ of NXP. MIPI™ of MIPI Alliance, Inc. MIPS™ of MIPS Technologies, Inc., USA. muRata™ of MURATA MANUFACTURING CO., MICROWAVE OFFICE™ (MWO) of Applied Wave Research Inc., OmniVision™ of OmniVision Technologies, Inc. Openwave™ Openwave Systems Inc. RED HAT™ Red Hat, Inc. RFMD™ RF Micro Devices, Inc. SIRIUS™ of Sirius Satellite Radio Inc. SOLARIS™ of Sun Microsystems, Inc. SPANSION™ of Spansion LLC Ltd. Symbian™ of Symbian Software Limited. TAIYO YUDEN™ of Taiyo Yuden Co. TEAKLITE™ of CEVA, Inc. TEKTRONIX™ of Tektronix Inc. TOKO™ of TOKO KABUSHIKI KAISHA TA. UNIX™ of X/Open Company Limited. VERILOG™, PALLADIUM™ of Cadence Design Systems, Inc. VLYNQ™ of Texas Instruments Incorporated. VXWORKS™, WIND RIVER™ of WIND RIVER SYSTEMS, INC. ZETEX™ of Diodes Zetex Limited.

Last Trademarks Update 2010-10-26

## Table of Contents

	<b>Table of Contents</b> .....	4
	<b>List of Figures</b> .....	5
	<b>List of Tables</b> .....	6
<b>1</b>	<b>Overview</b> .....	7
<b>2</b>	<b>Block Diagram</b> .....	9
<b>3</b>	<b>Pin Configuration and Functionality</b> .....	10
3.1	Pin Configuration .....	10
3.2	Pin Functionality .....	10
<b>4</b>	<b>Functional Description</b> .....	12
4.1	Introduction .....	12
4.2	Supply .....	12
4.3	Protection Features .....	12
4.3.1	Undervoltage Lockout (UVLO) .....	12
4.3.2	Active Shut-Down .....	12
4.3.3	Short Circuit Clamping .....	13
4.3.4	Active Miller Clamp .....	13
4.4	Non-Inverting and Inverting Inputs .....	13
4.5	Driver Output .....	13
<b>5</b>	<b>Electrical Parameters</b> .....	14
5.1	Absolute Maximum Ratings .....	14
5.2	Operating Parameters .....	15
5.3	Electrical Characteristics .....	15
5.3.1	Voltage Supply .....	15
5.3.2	Logic Input .....	16
5.3.3	Gate Driver .....	16
5.3.4	Short Circuit Clamping .....	17
5.3.5	Active Miller Clamp .....	17
5.3.6	Dynamic Characteristics .....	18
5.3.7	Active Shut Down .....	18
<b>6</b>	<b>Timing Diagrams</b> .....	19
<b>7</b>	<b>Package Outlines</b> .....	20
<b>8</b>	<b>Application Notes</b> .....	21
8.1	Reference Layout for Thermal Data .....	21
8.2	Printed Circuit Board Guidelines .....	21

## List of Figures

Figure 1	Typical Application . . . . .	8
Figure 2	Block Diagram 1EDI10I12MF, 1EDI20I12MF and 1EDI30I12MF . . . . .	9
Figure 3	PG-DSO-8-51 (top view) . . . . .	10
Figure 4	Application Example . . . . .	12
Figure 5	Propagation Delay, Rise and Fall Time . . . . .	19
Figure 6	Typical Switching Behavior . . . . .	19
Figure 7	UVLO Behavior . . . . .	19
Figure 8	PG-DSO-8-51 (Plastic (Green) Dual Small Outline Package) . . . . .	20
Figure 9	Reference Layout for Thermal Data (Copper thickness 35 µm) . . . . .	21

## List of Tables

Table 1	Pin Configuration .....	10
Table 2	Absolute Maximum Ratings .....	14
Table 3	Operating Parameters .....	15
Table 4	Voltage Supply .....	15
Table 5	Logic Input .....	16
Table 6	Gate Driver .....	16
Table 7	Short Circuit Clamping .....	17
Table 8	Active Miller Clamp .....	17
Table 9	Dynamic Characteristics .....	18
Table 10	Active Shut Down .....	18

## 1 Overview

### Main Features

- Single channel isolated IGBT Driver
- For 600 V/1200 V IGBTs
- Up to 6 A typical peak current at rail-to-rail outputs
- Active Miller Clamp

### Product Highlights

- Galvanically isolated Coreless Transformer Driver
- Wide input voltage operating range
- Suitable for operation at high ambient temperature

### Typical Application

- AC and Brushless DC Motor Drives
- High Voltage DC/DC-Converter and DC/AC-Inverter
- Induction Heating Resonant Application
- UPS-Systems
- Welding
- Solar

### Description

The 1EDI10I12MF, 1EDI20I12MF and 1EDI30I12MF are galvanically isolated single channel IGBT driver in a PG-DSO-8-51 package that provide minimum peak output currents up to 3 A and an integrated active Miller Clamp circuit with the same current rating to protect against parasitic turn on.

The input logic pins operate on a wide input voltage range from 3 V to 15 V using CMOS threshold levels to support even 3.3 V microcontroller.

Data transfer across the isolation barrier is realized by the Coreless Transformer Technology.

Every driver family member comes with logic input and driver output under voltage lockout (UVLO) and active shutdown.



Product Name	Gate Drive Current (min)	Package
1EDI10I12MF	±1.0 A with 1.0 A Miller Clamp	PG-DSO-8-51
1EDI20I12MF	±2.0 A with 2.0 A Miller Clamp	PG-DSO-8-51
1EDI30I12MF	±3.0 A with 3.0 A Miller Clamp	PG-DSO-8-51

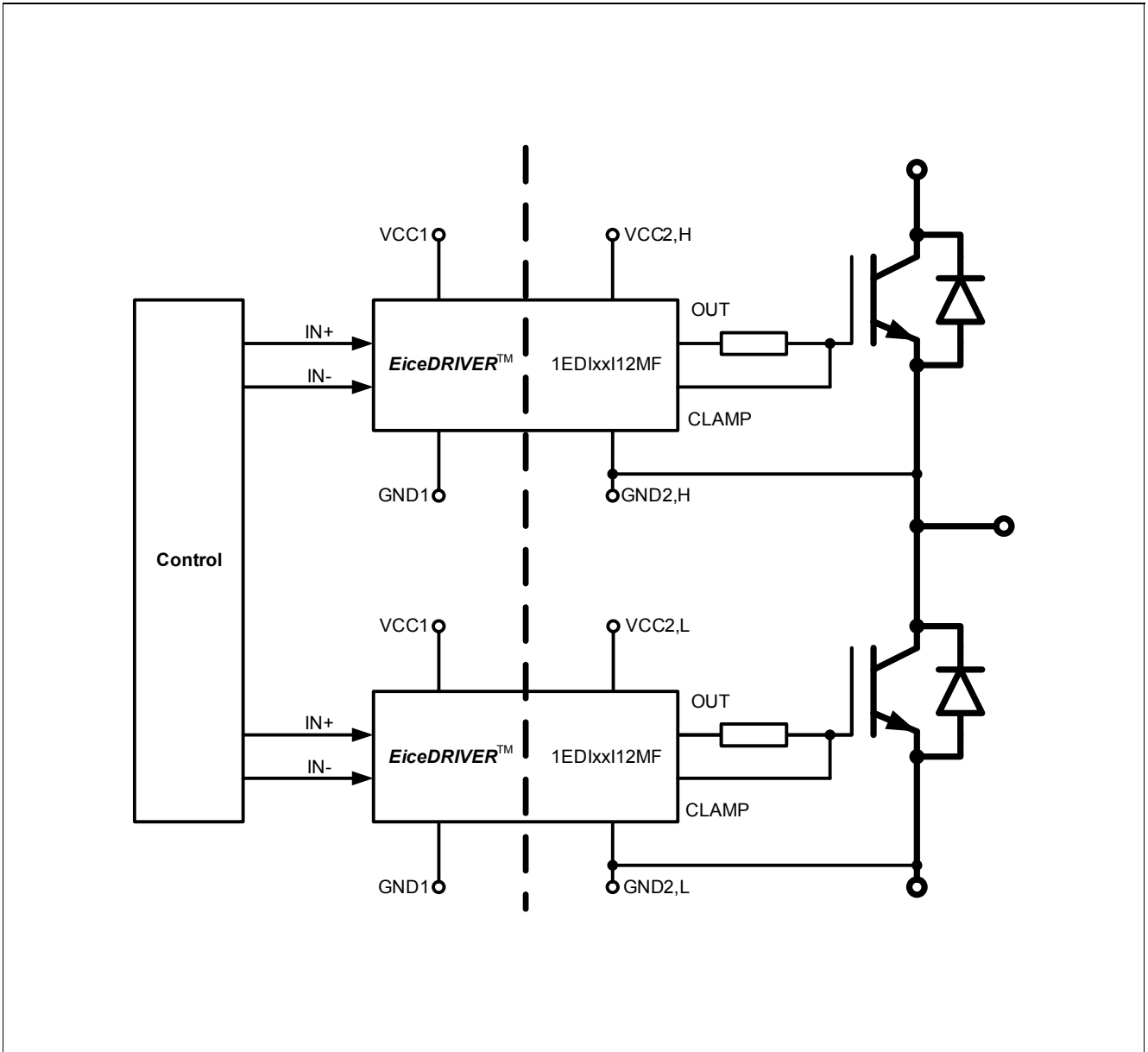

Figure 1 Typical Application



## 2 Block Diagram

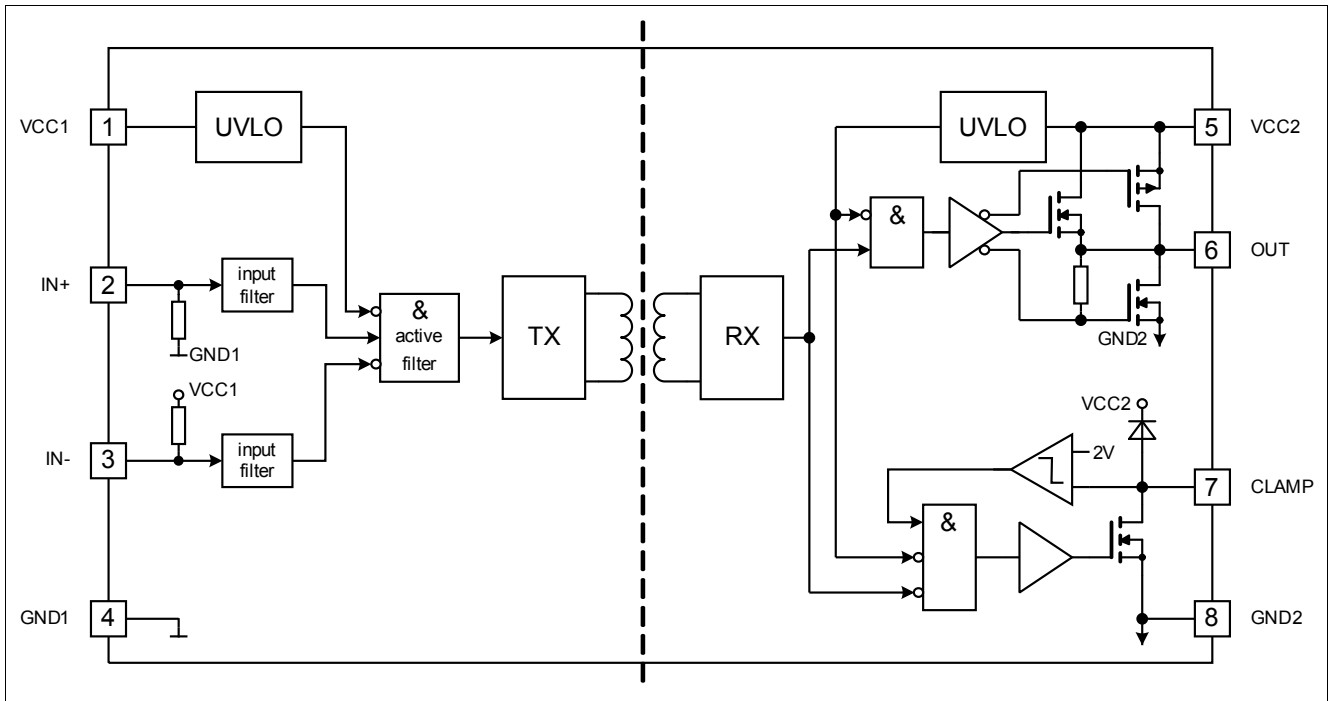

Figure 2 Block Diagram 1EDI10I12MF, 1EDI20I12MF and 1EDI30I12MF

### 3 Pin Configuration and Functionality

#### 3.1 Pin Configuration

Table 1 Pin Configuration

Pin No.	Name	Function
1	VCC1	Positive Logic Supply
2	IN+	Non-Inverted Driver Input (active high)
3	IN-	Inverted Driver Input (active low)
4	GND1	Logic Ground
5	VCC2	Positive Power Supply Output Side
6	OUT	Driver Output
7	CLAMP	Active Miller Clamp
8	GND2	Power Ground

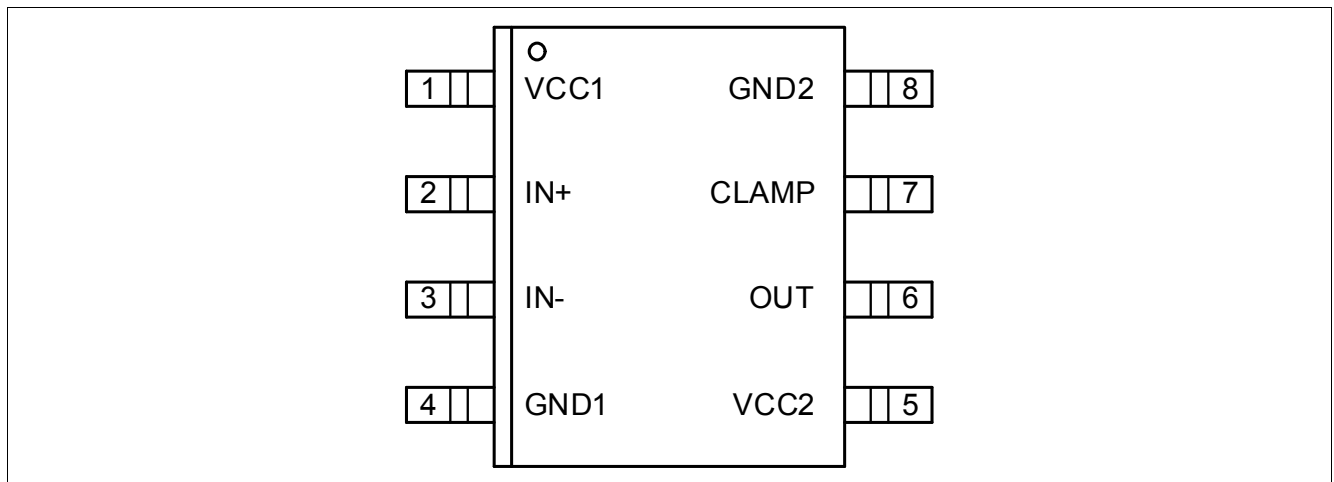

Figure 3 PG-DSO-8-51 (top view)

#### 3.2 Pin Functionality

##### VCC1

Logic input supply voltage of 3.3 V up to 15 V wide operating range.

##### IN+ Non Inverting Driver Input

IN+ non-inverted control signal for driver output if IN- is set to low. (Output sourcing active at IN+ = high and IN- = low)

Due to internal filtering a minimum pulse width is defined to ensure robustness against noise at IN+. An internal weak pull-down-resistor favors off-state.

**IN- Inverting Driver Input**

IN- inverted control signal for driver output if IN+ is set to high. (Output sourcing active at IN- = low and IN+ = high)  
Due to internal filtering a minimum pulse width is defined to ensure robustness against noise at IN-. An internal weak pull-up-resistor favors off-state.

**GND1**

Ground connection of input circuit.

**VCC2**

Positive power supply pin of output driving circuit. A proper blocking capacitor has to be placed close to this supply pin.

**OUT Driver Output**

Combined source and sink output pin to external IGBT. The output voltage will be switched between VCC2 and GND2 and is controlled by IN+ and IN-. In case of an UVLO event this output will be switched off and an active shut down keeps the output voltage at a low level.

**CLAMP Active Miller Clamp**

Connect gate of external IGBT directly to this pin. As soon as the gate voltage has dropped below 2 V referred to GND2 during turn off state the CLAMP function ties its output to GND2 to avoid parasitic turn on of the connected IGBT.

**GND2 Reference Ground**

Reference ground of the output driving circuit.

## 4 Functional Description

### 4.1 Introduction

The Output with Clamp variant for IGBT is a general purpose IGBT gate driver. Basic control and protection features support fast and easy design of highly reliable systems.

The integrated galvanic isolation between control input logic and driving output stage grants additional safety. Its wide input voltage supply range support the direct connection of various signal sources like DSPs and microcontrollers.

With the rail-to-rail output and the additional active miller clamp, dynamic turn on due to Miller capacitances are suppressed.

### 4.2 Supply

The driver can operate over a wide supply voltage range.

The typical positive supply voltage for the configuration in [Figure 4](#) is 15V at VCC2. Erratical dynamic turn on of the IGBT can be prevented with the active Miller clamp function, in which the CLAMP output is directly connected to the IGBT gate.

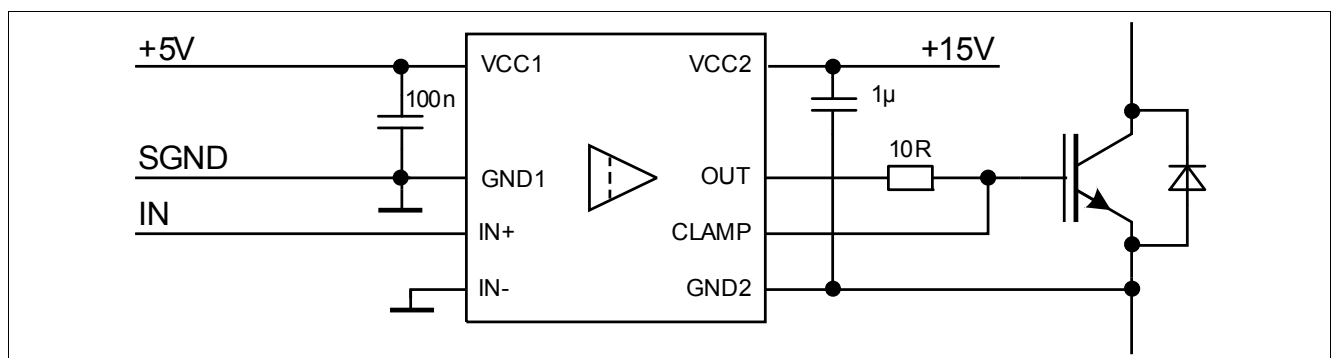

Figure 4 Application Example

### 4.3 Protection Features

#### 4.3.1 Undervoltage Lockout (UVLO)

To ensure correct switching of IGBTs the device is equipped with an undervoltage lockout for input and output independently. Operation starts only after both VCC levels have increased beyond the respective  $V_{UVLOH}$  levels (see also [Figure 7](#)).

If the power supply voltage  $V_{VCC1}$  of the input chip drops below  $V_{UVLOL1}$  a turn-off signal is sent to the output chip before power-down. The IGBT is switched off and the signals at IN+ and IN- are ignored until  $V_{VCC1}$  reaches the power-up voltage  $V_{UVLOH1}$  again.

If the power supply voltage  $V_{VCC2}$  of the output chip goes down below  $V_{UVLOL2}$  the IGBT is switched off and signals from the input chip are ignored until  $V_{VCC2}$  reaches the power-up voltage  $V_{UVLOH2}$  again.

#### 4.3.2 Active Shut-Down

The active shut-down feature ensures a safe IGBT off-state if the output chip is not connected to the power supply, IGBT gate is clamped at OUT and CLAMP to GND2.

### **4.3.3 Short Circuit Clamping**

During short circuit the IGBT's gate voltage tends to rise because of the feedback via the Miller capacitance. An additional protection circuit connected to OUT and CLAMP limits this voltage to a value slightly higher than the supply voltage. A maximum current of 500 mA may be fed back to the supply through one of these paths for 10  $\mu$ s. If higher currents are expected or tighter clamping is desired external Schottky diodes may be added.

### **4.3.4 Active Miller Clamp**

In a half bridge configuration the switched off IGBT tends to dynamically turn on during turn on phase of the opposite IGBT. A Miller clamp allows sinking the Miller current across a low impedance path in this high dV/dt situation. Therefore in many applications, the use of a negative supply voltage can be avoided.

During turn-off, the gate voltage is monitored and the clamp output is activated when the gate voltage drops below typical 2 V (referred to GND2). The clamp is designed for a Miller current in the same range as the nominal output current.

## **4.4 Non-Inverting and Inverting Inputs**

There are two possible input modes to control the IGBT. At non-inverting mode IN+ controls the driver output while IN- is set to low. At inverting mode IN- controls the driver output while IN+ is set to high, please see [Figure 6](#). A minimum input pulse width is defined to filter occasional glitches.

## **4.5 Driver Output**

The output driver section uses MOSFETs to provide a rail-to-rail output. This feature permits that tight control of gate voltage during on-state and short circuit can be maintained as long as the driver's supply is stable. Due to the low internal voltage drop, switching behaviour of the IGBT is predominantly governed by the gate resistor. Furthermore, it reduces the power to be dissipated by the driver.

## 5 Electrical Parameters

### 5.1 Absolute Maximum Ratings

Note: Absolute maximum ratings are defined as ratings, which when being exceeded may lead to destruction of the integrated circuit. Unless otherwise noted all parameters refer to GND1.

**Table 2 Absolute Maximum Ratings**

Parameter	Symbol	Values		Unit	Note / Test Condition
		Min.	Max.		
Power supply output side	$V_{VCC2}$	-0.3	20	V	1)
Gate driver output	$V_{OUT}$	$V_{GND2}-0.3$	$V_{VCC2}+0.3$	V	–
Pin CLAMP voltage	$V_{CLAMP}$	-0.3	$V_{VCC2}+0.3$ <sup>1)</sup>	V	1)
Maximum short circuit clamping time	$t_{CLP}$	–	10	µs	$I_{CLAMP/OUT} = 500 \text{ mA}$
Positive power supply input side	$V_{VCC1}$	-0.3	18.0	V	–
Logic input voltages (IN+,IN-)	$V_{LogicIN}$	-0.3	18.0	V	–
Input to output isolation voltage (GND2)	$V_{ISO}$	-1200	1200	V	
Junction temperature	$T_J$	-40	150	°C	–
Storage temperature	$T_S$	-55	150	°C	–
Power dissipation (Input side)	$P_{D, IN}$	–	25	mW	2) @ $T_A = 25^\circ\text{C}$
Power dissipation (Output side)	$P_{D, OUT}$	–	400	mW	2) @ $T_A = 25^\circ\text{C}$
Thermal resistance (Input side)	$R_{THJA, IN}$	–	145	K/W	2) @ $T_A = 85^\circ\text{C}$
Thermal resistance (Output side)	$R_{THJA, OUT}$	–	165	K/W	2) @ $T_A = 85^\circ\text{C}$
ESD capability	$V_{ESD, HBM}$	–	2	kV	Human Body Model <sup>3)</sup>

1) May be exceeded during short circuit clamping.

2) See **Figure 9** for reference layouts for these thermal data. Thermal performance may change significantly with layout and heat dissipation of components in close proximity.

3) According to EIA/JESD22-A114-C (discharging a 100 pF capacitor through a 1.5 kΩ series resistor).

## 5.2 Operating Parameters

Note: Within the operating range the IC operates as described in the functional description. Unless otherwise noted all parameters refer to GND1.

**Table 3 Operating Parameters**

Parameter	Symbol	Values		Unit	Note / Test Condition
		Min.	Max.		
Power supply output side	$V_{VCC2}$	13	18	V	1)
Power supply input side	$V_{VCC1}$	3.1	17	V	–
Logic input voltages (IN+,IN-)	$V_{LogicIN}$	-0.3	17	V	–
Pin CLAMP voltage	$V_{CLAMP}$	$V_{GND2}-0.3$	$V_{VCC2}^{2)}$	V	–
Switching frequency	$f_{sw}$	–	1.0	MHz	3) 4)
Ambient temperature	$T_A$	-40	125	°C	–
Thermal coefficient, junction-top	$\Psi_{th,jt}$	–	4.8	K/W	@ $T_A = 85^\circ\text{C}$
Common mode transient immunity	$ dV_{ISO}/dt $	–	100	kV/ $\mu\text{s}$	4) @ 1000 V

1) With respect to GND2.

2) May be exceeded during short circuit clamping.

3) do not exceed max. power dissipation

4) Parameter is not subject to production test - verified by design/characterization

## 5.3 Electrical Characteristics

Note: The electrical characteristics include the spread of values in supply voltages, load and junction temperatures given below. Typical values represent the median values at  $T_A = 25^\circ\text{C}$ . Unless otherwise noted all voltages are given with respect to their respective GND (GND1 for pins 1 to 3, GND2 for pins 5 to 7).

### 5.3.1 Voltage Supply

**Table 4 Voltage Supply**

Parameter	Symbol	Values			Unit	Note / Test Condition
		Min.	Typ.	Max.		
UVLO threshold input chip	$V_{UVLOH1}$	–	2.85	3.1	V	–
	$V_{UVLOL1}$	2.55	2.75	–	V	–
UVLO hysteresis input chip ( $V_{UVLOH1} - V_{UVLOL1}$ )	$V_{HYS1}$	90	100	–	mV	–
UVLO threshold output chip (IGBT supply)	$V_{UVLOH2}$	–	11.9	12.7	V	–
	$V_{UVLOL2}$	10.5	11.0	–	V	–
UVLO hysteresis output chip ( $V_{UVLOH1} - V_{UVLOL1}$ )	$V_{HYS2}$	700	850	–	mV	–

**Table 4 Voltage Supply (cont'd)**

Parameter	Symbol	Values			Unit	Note / Test Condition
		Min.	Typ.	Max.		
Quiescent current input chip	$I_{Q1}$	–	0.6	1.0	mA	$V_{VCC1} = 5\text{ V}$ IN+ = High, IN- = Low =>OUT = High
Quiescent current output chip	$I_{Q2}$	–	1.2	2.0	mA	$V_{VCC2} = 15\text{ V}$ IN+ = High, IN- = Low =>OUT = High

### 5.3.2 Logic Input

Note: Unless stated otherwise  $V_{CC1} = 5.0\text{V}$

**Table 5 Logic Input**

Parameter	Symbol	Values			Unit	Note / Test Condition
		Min.	Typ.	Max.		
IN+,IN- low input voltage	$V_{IN+L}, V_{IN-L}$	–	–	30	%	of VCC1
IN+,IN- high input voltage	$V_{IN+H}, V_{IN-H}$	70	–	–	%	of VCC1
IN+,IN- low input voltage	$V_{IN+L}, V_{IN-L}$	–	–	1.5	V	–
IN+,IN- high input voltage	$V_{IN+H}, V_{IN-H}$	3.5	–	–	V	–
IN- input current	$I_{IN-}$	–	70	200	$\mu\text{A}$	$V_{IN-} = \text{GND1}$
IN+ input current	$I_{IN+}$	–	70	200	$\mu\text{A}$	$V_{IN+} = V_{CC1}$

### 5.3.3 Gate Driver

**Table 6 Gate Driver**

Parameter	Symbol	Values			Unit	Note / Test Condition
		Min.	Typ.	Max.		
High level output peak current (source) 1EDI10I12MF 1EDI20I12MF 1EDI30I12MF	$I_{OUT,H,PEAK}$	1.0 2.0 3.0	– 2.2 4.4 5.9	–	A	1) IN+ = High, IN- = Low, $V_{VCC2} = 15\text{ V}$
Low level output peak current (sink) 1EDI10I12MF 1EDI20I12MF 1EDI30I12MF	$I_{OUT,L,PEAK}$	1.0 2.0 3.0	– 2.3 4.1 6.2	–	A	1) IN+ = Low, IN- = Low, $V_{VCC2} = 15\text{ V}$

1) voltage across the device  $V_{(VCC2 - OUT+)}$  or  $V_{(OUT- - GND2)} < V_{VCC2}$ .



### 5.3.4 Short Circuit Clamping

**Table 7 Short Circuit Clamping**

Parameter	Symbol	Values			Unit	Note / Test Condition
		Min.	Typ.	Max.		
Clamping voltage (OUT) ( $V_{OUT} - V_{VCC2}$ )	$V_{CLPout}$	–	0.9	1.3	V	IN+ = High, IN- = Low, $I_{OUT} = 500$ mA pulse test, $t_{CLPmax} = 10$ $\mu$ s)
Clamping voltage (CLAMP) ( $V_{VCLAMP} - V_{VCC2}$ )	$V_{CLPclamp1}$	–	1.3	–	V	IN+ = High, IN- = Low, $I_{CLAMP} = 500$ mA (pulse test, $t_{CLPmax} = 10$ $\mu$ s)
Clamping voltage (CLAMP)	$V_{CLPclamp2}$	–	0.7	1.1	V	IN+ = High, IN- = Low, $I_{CLAMP} = 20$ mA

### 5.3.5 Active Miller Clamp

**Table 8 Active Miller Clamp**

Parameter	Symbol	Values			Unit	Note / Test Condition
		Min.	Typ.	Max.		
Low level clamp current 1EDI10I12MF 1EDI20I12MF 1EDI30I12MF	$I_{CLAMP,PEAK}$	1.0 2.0 3.0	–	–	A	1) IN+ = Low, IN- = Low, $V_{CLAMP} = 15$ V pulsed $t_{pulse} = 2$ $\mu$ s
Clamp threshold voltage	$V_{CLAMP}$	1.6	2.0	2.4	V	Related to GND2

1) The parameter is not subject to production test - verified by design/characterization

### 5.3.6 Dynamic Characteristics

Dynamic characteristics are measured with  $V_{VCC1} = 5\text{ V}$  and  $V_{VCC2} = 15\text{ V}$ .

**Table 9 Dynamic Characteristics**

Parameter	Symbol	Values			Unit	Note / Test Condition
		Min.	Typ.	Max.		
Input IN to output propagation delay ON	$T_{PDON}$	270	300	330	ns	$C_{LOAD} = 100\text{ pF}$ $V_{IN+} = 50\%$ , $V_{OUT}=50\%$ @ 25°C
Input IN to output propagation delay OFF	$T_{PDOFF}$	270	300	330	ns	
Input IN to output propagation delay distortion ( $T_{PDOFF} - T_{PDON}$ )	$T_{PDISTO}$	-30	5	40	ns	
Input pulse suppression IN+, IN-	$T_{MININ+}$ , $T_{MININ-}$	230	240	–	ns	–
IN input to output propagation delay ON variation due to temp	$T_{PDONT}$	–	–	14	ns	<sup>1)</sup> $C_{LOAD} = 100\text{ pF}$ $V_{IN+} = 50\%$ , $V_{OUT}=50\%$
IN input to output propagation delay OFF variation due to temp	$T_{PDOFFt}$	–	–	14	ns	<sup>1)</sup> $C_{LOAD} = 100\text{ pF}$ $V_{IN+} = 50\%$ , $V_{OUT}=50\%$
IN input to output propagation delay distortion variation due to temp ( $T_{PDOFF}-T_{PDON}$ )	$T_{PDISTOt}$	–	–	8	ns	<sup>1)</sup> $C_{LOAD} = 100\text{ pF}$ $V_{IN+} = 50\%$ , $V_{OUT}=50\%$
Rise time	$T_{RISE}$	5	9	19	ns	$C_{LOAD} = 1\text{ nF}$ $V_L 20\%$ , $V_H 80\%$
Fall time	$T_{FALL}$	3	6	15	ns	$C_{LOAD} = 1\text{ nF}$ $V_L 20\%$ , $V_H 80\%$

1) The parameter is not subject to production test - verified by design/characterization

### 5.3.7 Active Shut Down

**Table 10 Active Shut Down**

Parameter	Symbol	Values			Unit	Note / Test Condition
		Min.	Typ.	Max.		
Active shut down voltage	$V_{ACTSD}$ <sup>1)</sup>	–	1.8	2.0	V	$I_{OUT}/I_{OUT,PEAK}=0.1$ , $V_{CC2}$ open

1) With reference to GND2

## 6 Timing Diagramms

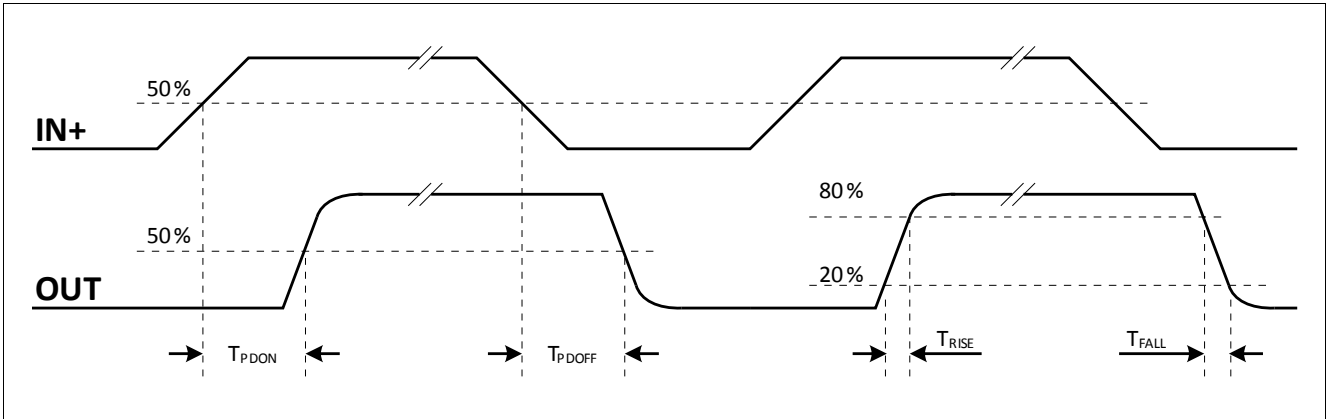

Figure 5 Propagation Delay, Rise and Fall Time

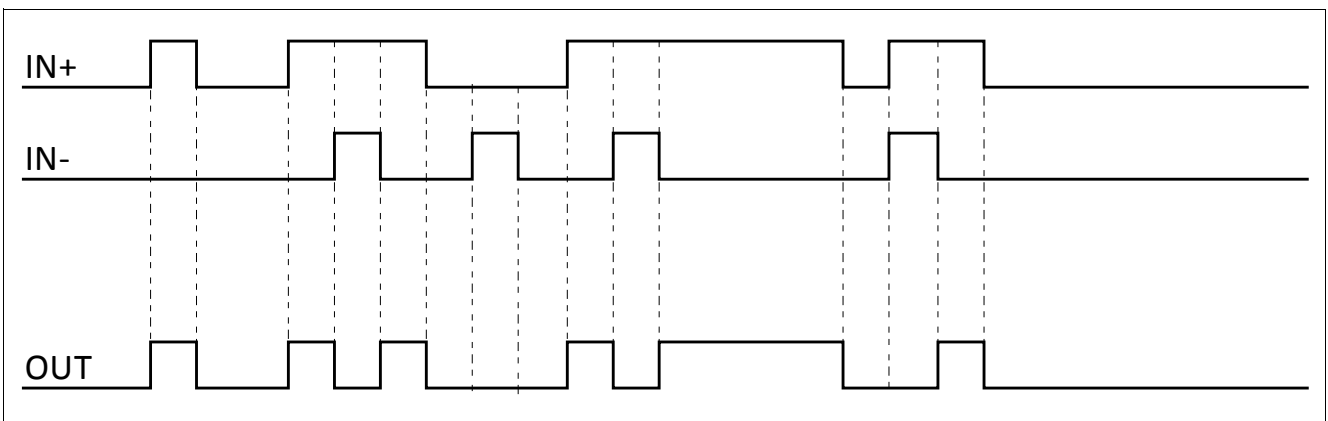

Figure 6 Typical Switching Behavior

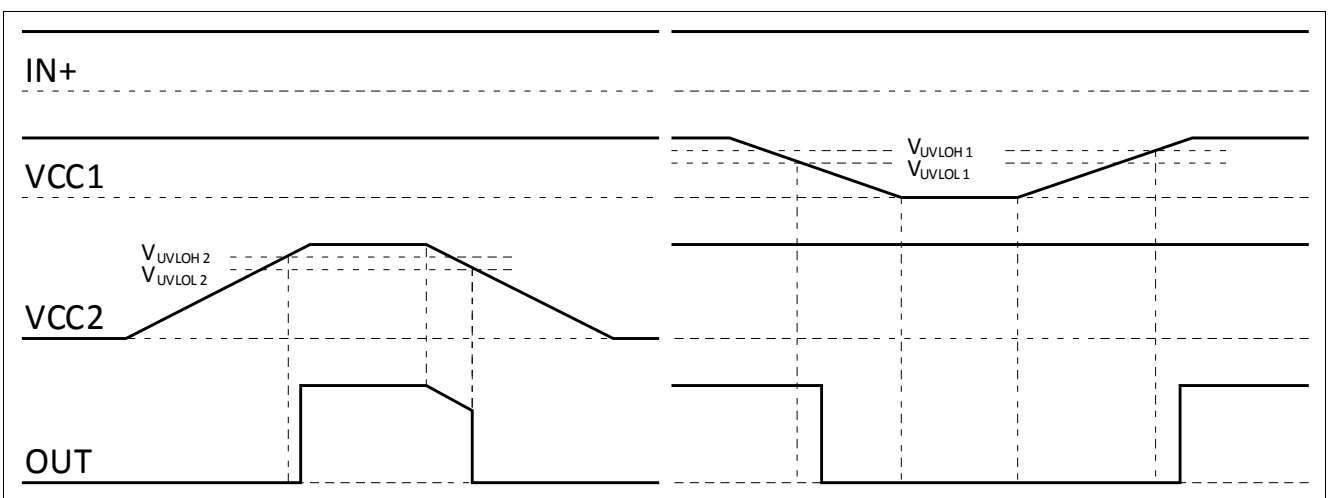

Figure 7 UVLO Behavior

7 Package Outlines



Figure 8 PG-DSO-8-51 (Plastic (Green) Dual Small Outline Package)

## 8 Application Notes

### 8.1 Reference Layout for Thermal Data

The PCB layout shown in **Figure 9** represents the reference layout used for the thermal characterisation. Pin 4 (GND1) and pin 8 (GND2) require each a ground plane of 100 mm<sup>2</sup> for achieving maximum power dissipation. The Output with Clamp variant for IGBT is conceived to dissipate most of the heat generated through this pins.

The thermal coefficient junction-top ( $\Psi_{th,jt}$ ) can be used to calculate the junction temperature at a given top case temperature and driver power dissipation:

$$T_j = \Psi_{th,jt} \cdot P_D + T_{top}$$



**Figure 9** Reference Layout for Thermal Data (Copper thickness 35 μm)

### 8.2 Printed Circuit Board Guidelines

The following factors should be taken into account for an optimum PCB layout.

- Sufficient spacing should be kept between high voltage isolated side and low voltage side circuits.
- The same minimum distance between two adjacent high-side isolated parts of the PCB should be maintained to increase the effective isolation and to reduce parasitic coupling.
- In order to ensure low supply ripple and clean switching signals, bypass capacitor trace lengths should be kept as short as possible.

[www.infineon.com](http://www.infineon.com)

Published by Infineon Technologies AG