

THIS DOCUMENT IS THE PROPERTY OF KEYSTONE ELECTRONICS CORP. AND SHALL NOT BE REPRODUCED, DISTRIBUTED OR USED AS A BASIS FOR MANUFACTURE WITHOUT PRIOR WRITTEN PERMISSION FROM KEYSTONE ELECTRONICS CORP.

ACTUAL SIZE

MOUNTING DETAIL

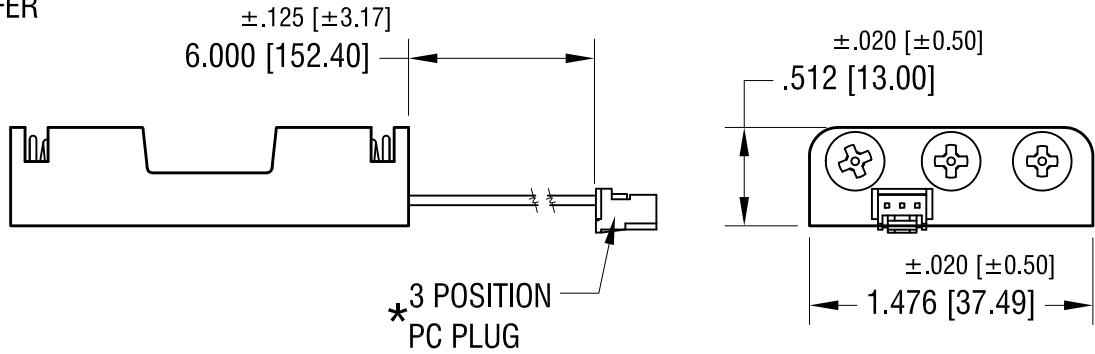
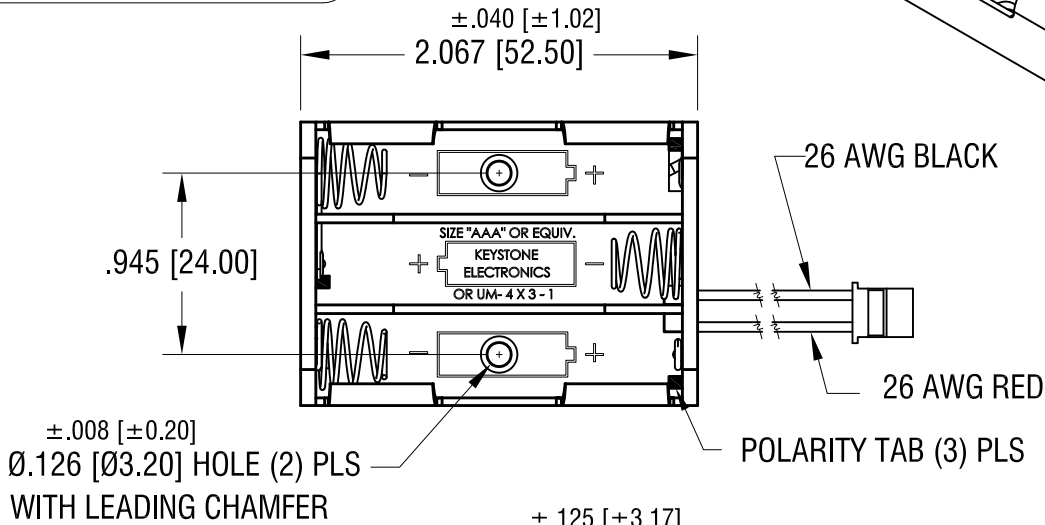
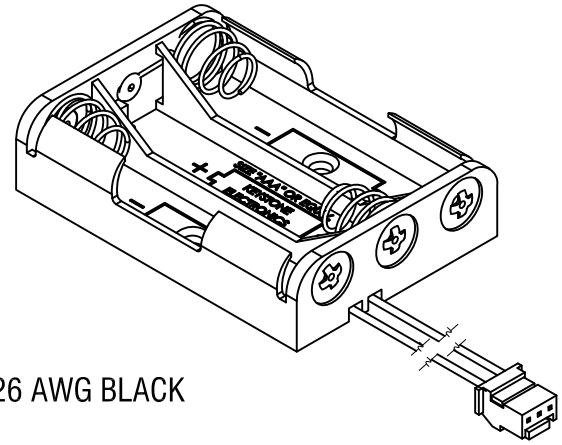
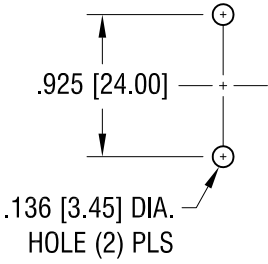

NOTE:

1. HOLDER: MAT'L: POLYPROPYLENE
2. SPRING: MAT'L: MUSIC WIRE, .024 [0.60] DIA. FINISH- NICKEL PLATE
3. #26 AWG WIRE, UL/CSA 1007
4. CONNECTOR: MAT'L - PA 66, UL94V-0

5. POSITIVE (RED) CONNECTED TO PIN 1
 NEGATIVE (BLACK) CONNECTED TO PIN 3
 COLOR- NATURAL

*USE : P/N'S 974,975, 976 OR 977 FOR P.C. CONNECTOR

12.16.21	CHANGE AS PER ECN 21-187	A
DATE	DESCRIPTION	REV.

KEYSTONE ELECTRONICS CORP.			
www.keyelco.com • NEW HYDE PARK NY 11040 • Tel (516)328-7500			
PART NAME PC BATTERY HOLDER (3) 'AAA'			
MATERIAL AS NOTED			
FINISH AS NOTED		DRN BY NT	DATE 4.08.16
		APP'D RH	SCALE 1X
TOLERANCES	INCH [MM]	CODE	DWG NO.
DECIMAL	±.010 [±0.25]	C	
ANGULAR	± 1°		
UNLESS OTHERWISE SPECIFIED			
			2480CN